

FLUID POWER LAB

Name _____

Set: _____ Date: _____

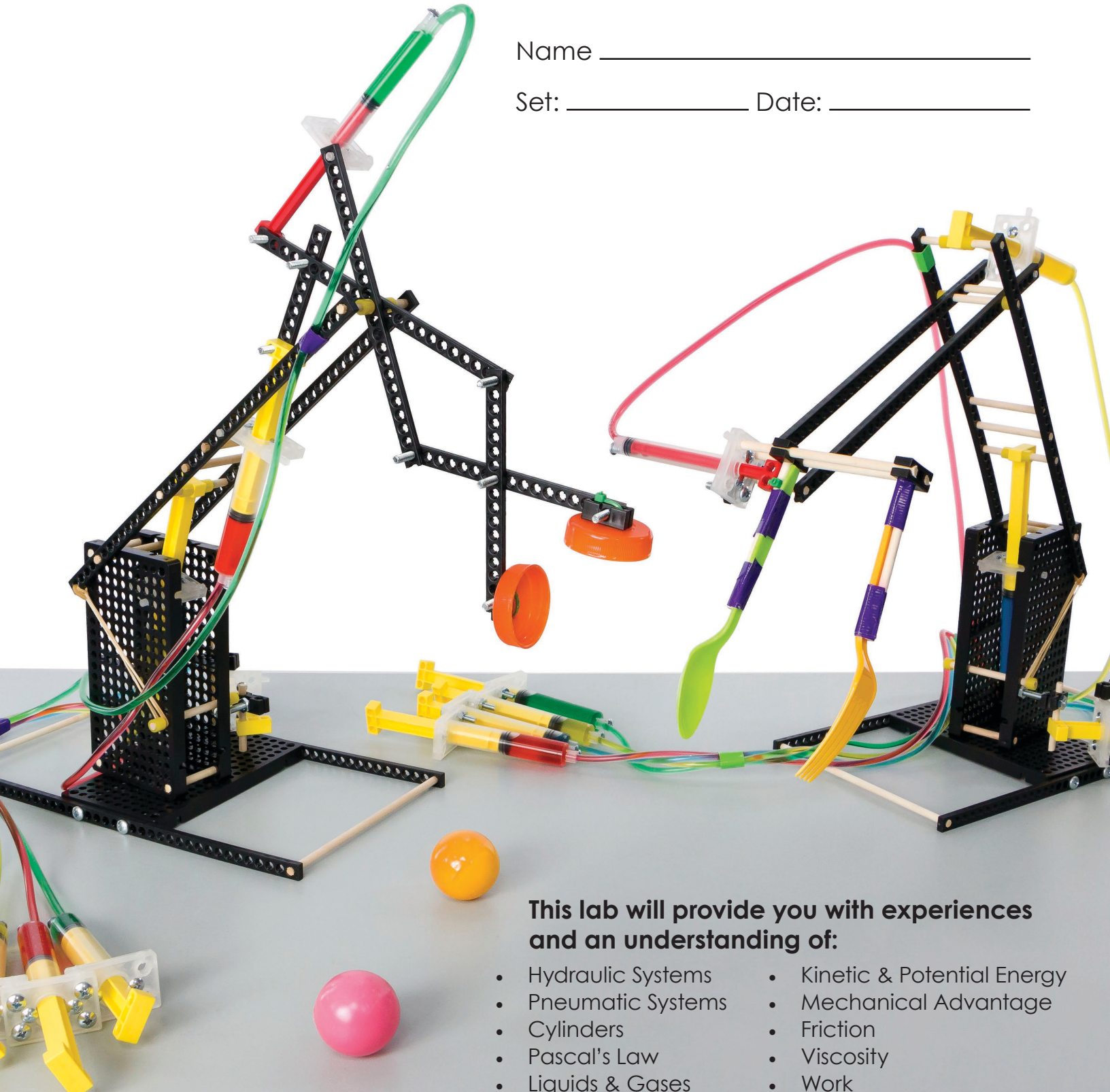

This lab will provide you with experiences and an understanding of:

- Hydraulic Systems
- Pneumatic Systems
- Cylinders
- Pascal's Law
- Liquids & Gases
- Pressure
- Kinetic & Potential Energy
- Mechanical Advantage
- Friction
- Viscosity
- Work

TEACHERGEEK SUPPLIES YOU'LL NEED

Cut or find tubing the following lengths to use later in **Activity Build Guides** and **Design & Engineering Challenges**. Do not connect anything yet. First we're going to experiment a bit with pressure.

Fluid Power Activity Pack/Maker Cart

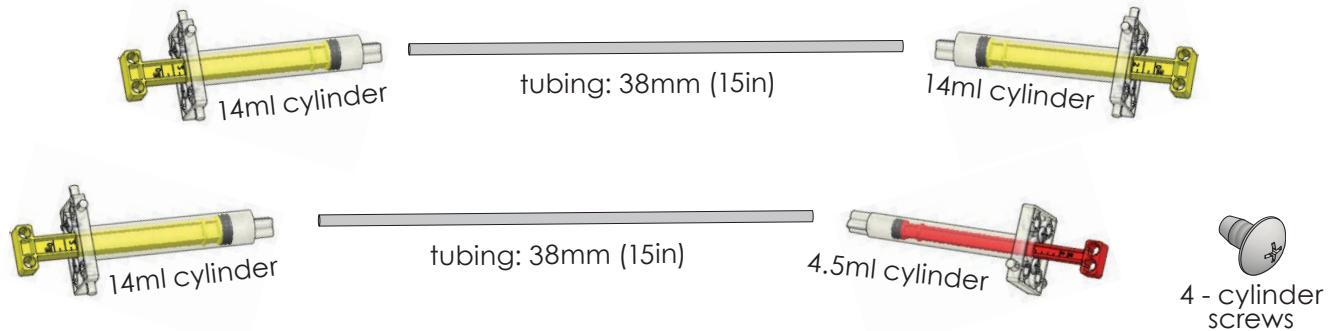

Hydraulic Arm - Basic

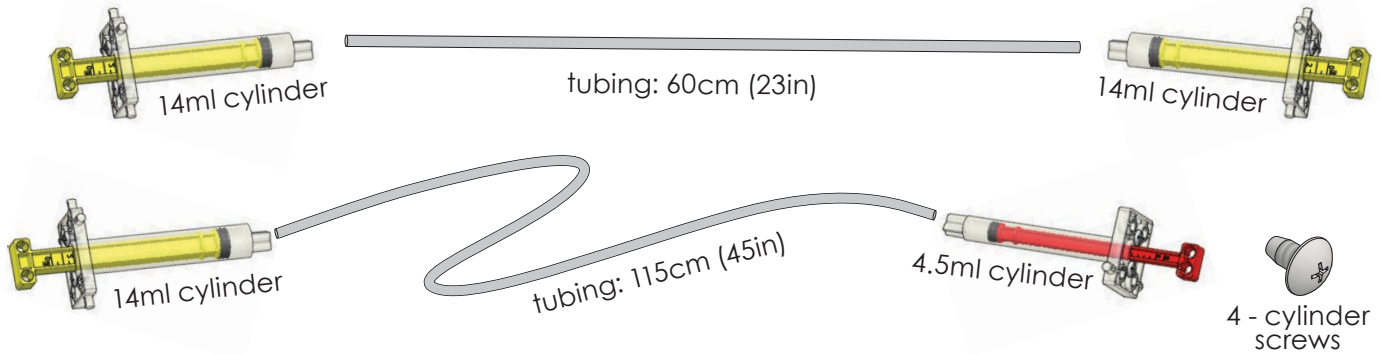

Hydraulic Arm - Advanced

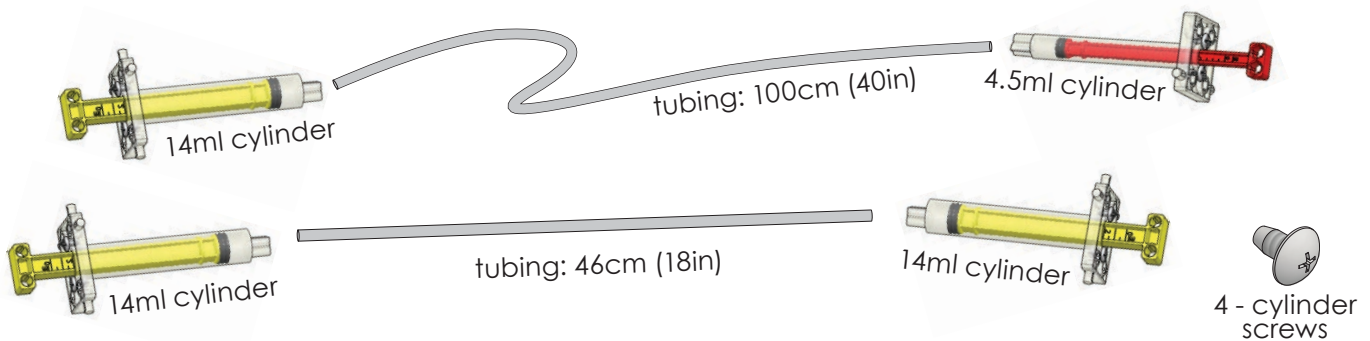

When it's time, refer to the end of this lab for help assembling your pneumatic and hydraulic systems.

FLUID POWER

Fluid power is an area of technology dealing with the generation, control, and transmission of pressurized fluids. A fluid can be a **gas** or a **liquid**.

PNEUMATICS

Pneumatic systems use a **gas** to transmit and store power.

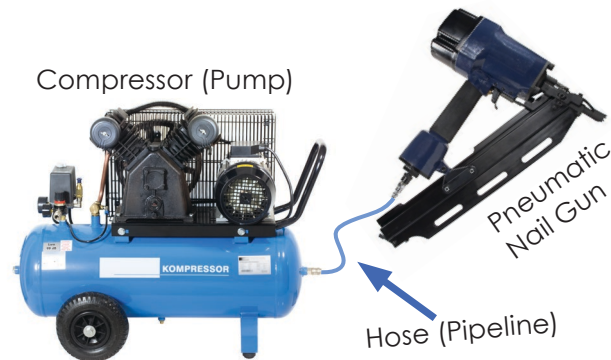

HYDRAULICS

Hydraulic systems use a **liquid** to transmit power.

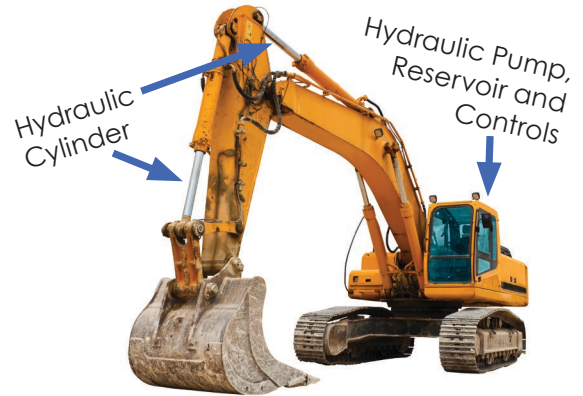

Pneumatic Devices

1. List two devices, other than the ones above, that use **pneumatics** for operation. Describe how they use pneumatics.

Device

How does it use pneumatics?

A Few Examples - air brakes on buses, trucks and trains; air compressors/pneumatic tools; inflatable toys and bouncy castles; pipe organs; pneumatic air guns, nailers, sanders, grinders, wrenches, drills; pneumatic tires; jackhammer

Hydraulic Devices

2. List two devices, other than the ones above, that use **hydraulics** for operation. Describe how they use hydraulics.

Device

How does it use hydraulics?

A Few Examples - heavy equipment: backhoe, loader, forklift, crane, bulldozer, excavator; control surfaces on planes; car brakes; hydrostatic transmission; hydraulic robots

CYLINDERS

Cylinders transform pressure and fluid-flow into **mechanical force**.



Anatomy of a Cylinder

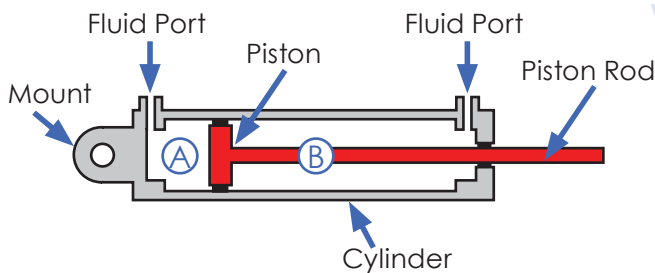

Chambers **A** and **B** are sealed, fluids can only enter or exit through the ports. Pressure in a chamber creates a force on the piston.

Double-Acting Cylinders

Most cylinders are **double-acting**. Double-acting cylinders allow pressurized fluid to flow on either side of the piston, allowing it to be powered in both directions.

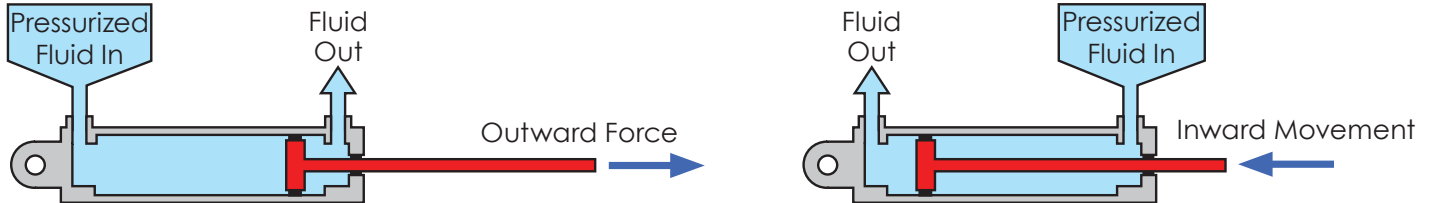

Single-Acting Cylinders

Single-acting cylinders are only powered in one direction. The piston is returned by the weight of the load or a spring.

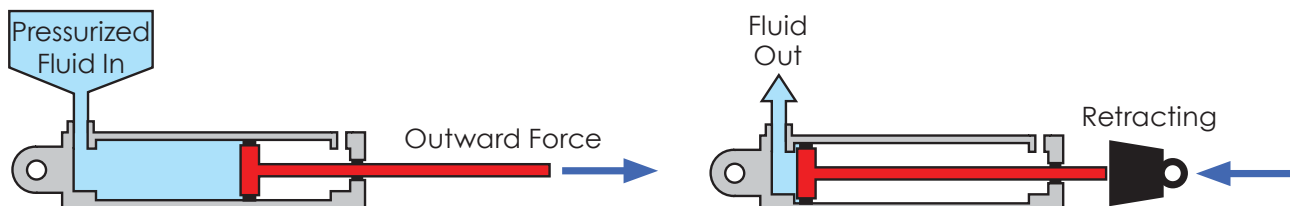

The pumps that power cylinders can usually only create a **positive fluid pressure** (push fluid). That is why most cylinders, like the ones shown above, are designed to only be powered by positive fluid pressure.

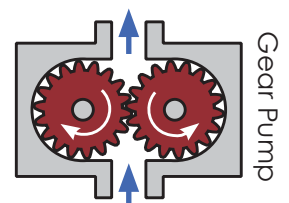

Your Cylinders Will Push & Pull

You will use a cylinder as a pump. The cylinder will be able to **push** fluid (creating a positive pressure), or **pull** fluid (creating a negative pressure). This will allow your cylinders with a single port to be powered in both directions.

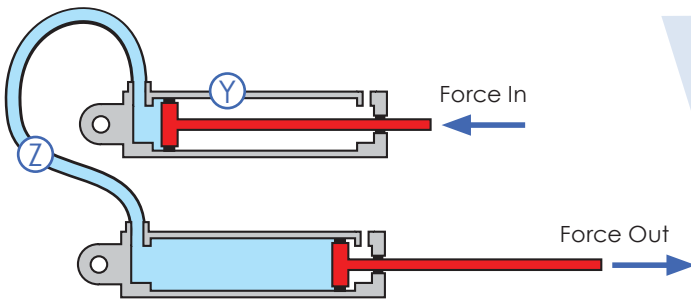

✓ the correct answers below:

1. There is a Positive Negative pressure in line Z.
2. Cylinder Y is Pulling Pushing fluid.

Know Your Parts

3. Match the components with their name by placing letters into the boxes below.

Piston:

C

Piston Rod:

D

Cylinder:

B

Fluid Port:

A

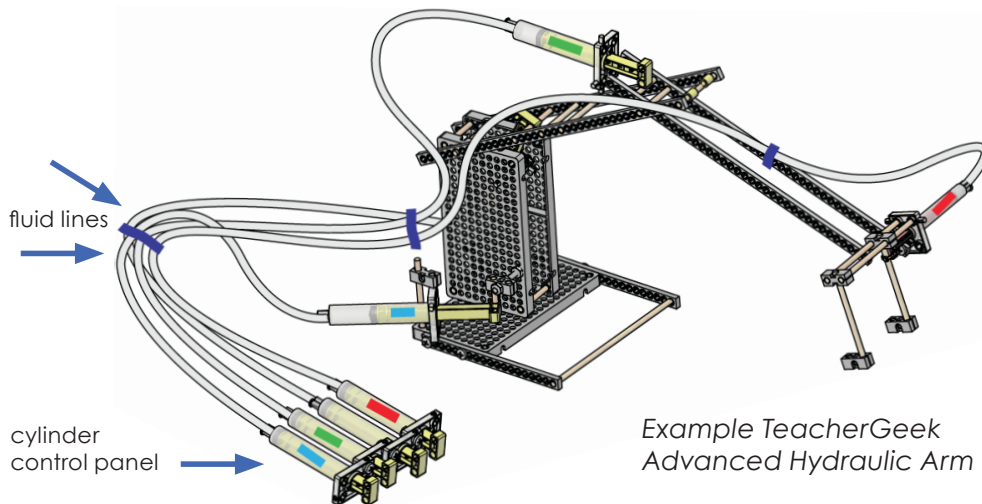
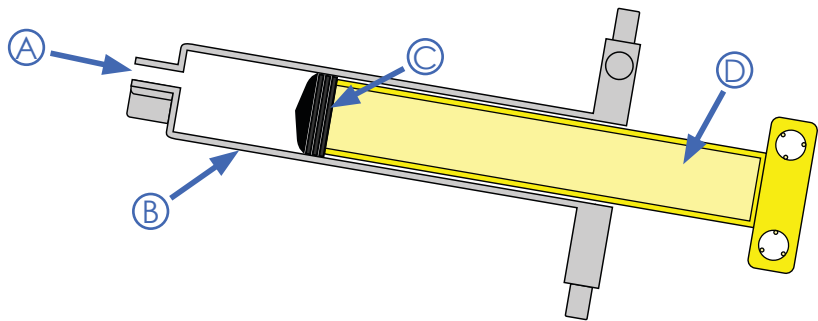

Example TeacherGeek Advanced Hydraulic Arm

WHAT IS PRESSURE?

Pressure is a force applied over an area:

$$\text{Pressure} = \frac{\text{Force}}{\text{Area}}$$

The area over which the force is applied. ↑

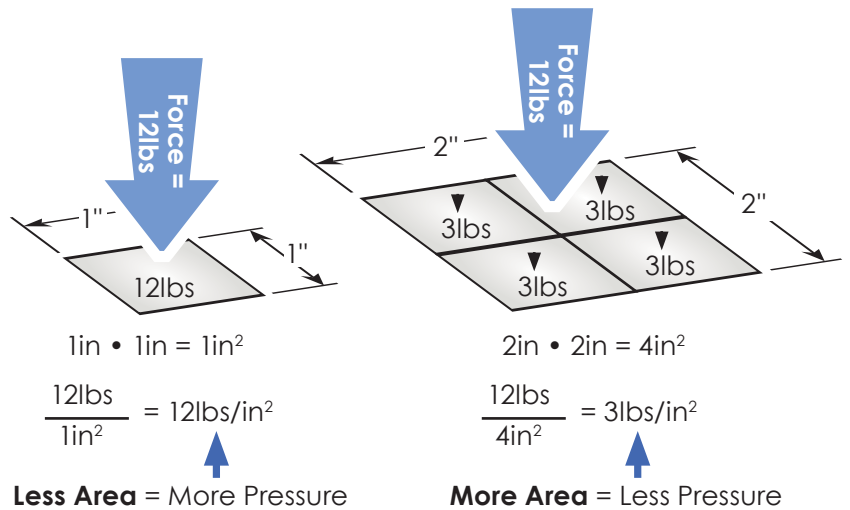

Step One

Push the **piston end** of a cylinder against your hand.

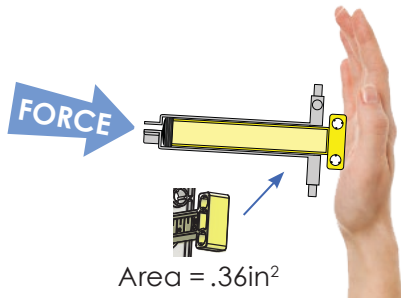

Step Two

Push the **fluid port** end of a cylinder against your hand.

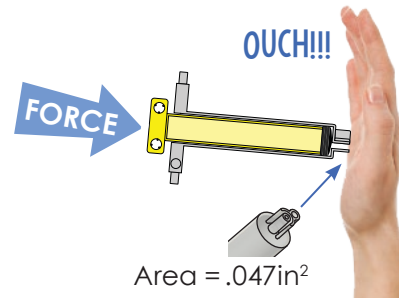

4. Both ends of the cylinder were pushed against your hand with the same force. Explain why they felt different? **HINT:** Pressure = Force/Area

Step 1: The large piston end has a lot of area to spread (distribute) the force over, so the pressure is less.

Step 2: The small end of the port does not have a lot of area to spread the force over, so the pressure is great.

Putting Your Foot Down

A foot pushes down on a 3in³ cube with 45lbs of force.

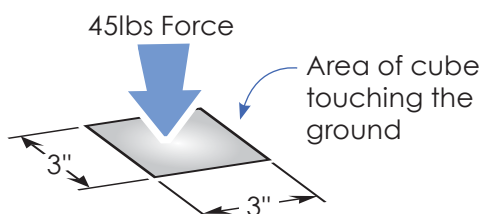

5. How much pressure does the cube apply to the ground? Show your work.

$$\frac{45\text{lbs}}{9\text{in}^2} = 5\text{lbs/in}^2$$

Answer: 5lbs/in²

FIND THE UNKNOWN

Let's look at another way to write the formula:

Pressure = $\frac{\text{Force}}{\text{Area}}$ can be written as:

Use this chart to find the formula to calculate a **missing variable** (force, pressure, area).

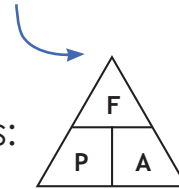

P = Pressure
F = Force
A = Area

Cover the missing variable on the chart to find the formula to calculate it:

You know: Pressure, Area
You need to find: Force

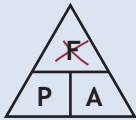

Force = Pressure • Area

You know: Force, Area
You need to find: Pressure



Pressure = Force/Area

You know: Pressure, Force
You need to find: Area

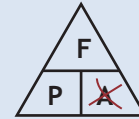

Area = Force / Pressure

6. Pressure transfers between the piston and the fluid in the cylinder.
Calculate the force of the piston when the fluid applies 20lbs/in² to it.

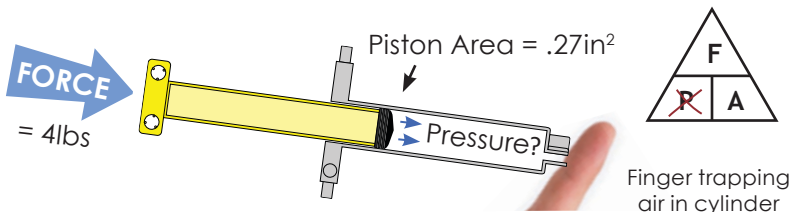

Show your work.

$$\frac{4\text{lbs}}{.27\text{in}^2} = 14.814\text{psi}$$

Answer: 14.81 psi

MEASUREMENTS OF PRESSURE

lbs/in² (psi)

A force of 1 pound applied over an area of 1 square inch produces a pressure of 1 pound per square inch (1lb/in²)

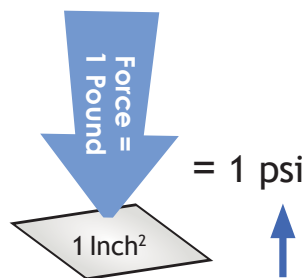

pounds per square inch can be abbreviated as "**psi**"

Pascal (Pa)

A force of 1 newton applied over an area of 1 square meter produces a pressure of 1 pascal.

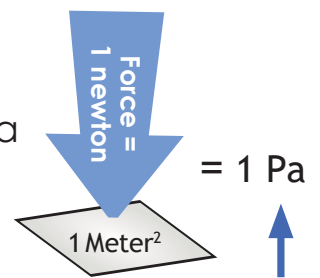

Pascal can be abbreviated as "**Pa**"

PASCAL'S LAW

Pascal's Law: a confined fluid transmits an externally applied pressure uniformly in all directions.

Piston **(A)** applies pressure to the fluid inside chamber **(B)**. The fluid transmits the pressure in every direction and to every surface it touches.

7. If the pressure is 5psi in chamber **(B)**, what is the pressure in line **(C)** and chamber **(D)** ?

Answer: psi

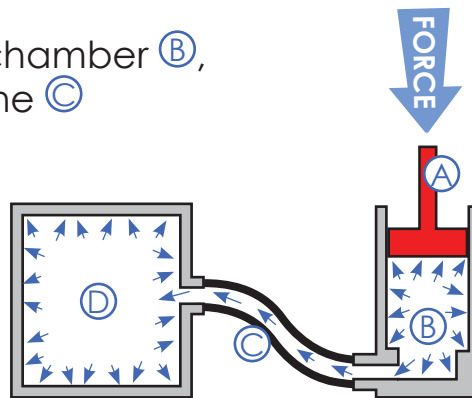

Squeezing a toothpaste tube is an example of **Pascal's Law**. Squeezing applies **external pressure** to the toothpaste fluid inside. The toothpaste transmits the force equally **in all directions**, pushing paste out and making the tube walls bulge.

Pressurizing Marshmallows

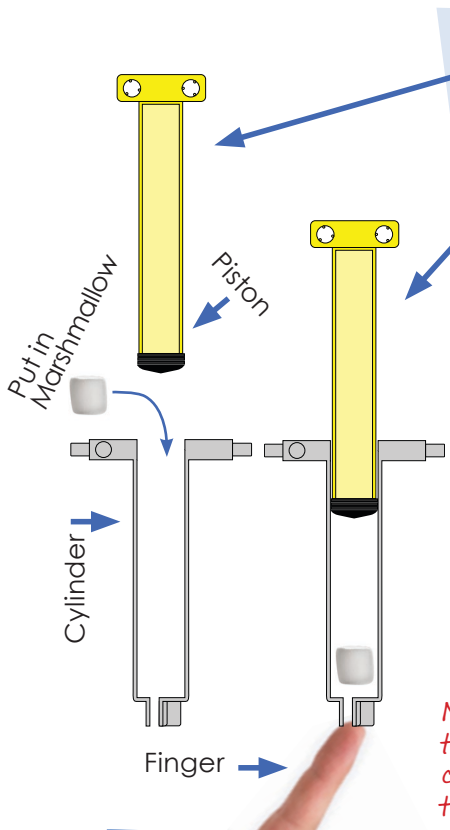

- A** Pull the piston out from the cylinder and place one small marshmallow inside the chamber.
- B** Push the piston in while covering the fluid port with your finger. *What happens to the marshmallow?*
- C** Push the piston in with your finger off the port.
- D** Put your finger over the port and pull the piston back. Watch the marshmallow.

8. What happened to the marshmallow?
Answer: Pressure transferred from the piston, through the fluid, to the marshmallow.

9. Why, according to **Pascal's Law**, did the marshmallow equally grow and shrink on all sides?

Note: The gas inside the marshmallow expands and contracts relating to the outside pressure acting on it. When the pressure inside the cylinder is reduced, the marshmallow expands. When pressure inside the cylinder is increased, the marshmallow contracts.

CALCULATING PRESSURE

Example Calculation

Force = 20 lbs

NOTE: Numbers used in this example are not real cylinder values. They are for example purposes only.

1 Calculate the Area of the Piston

0.3in Radius

$$\text{Area} = \pi \cdot \text{Radius}^2$$

$$3.14 \cdot 0.3\text{in} \cdot 0.3\text{in}$$

$$\text{Area} = 0.28\text{in}^2$$

2 Calculate Pressure

F	→	20lbs
P	→	.28in ²
A	→	=
71.4lbs/in ²		

Your Calculation

Force = 7 lbs

10. Calculate the pressure inside the cylinder.

Formulas:

Area of a circle = $\pi \cdot \text{Radius}^2$

F	→	P = Pressure
P	→	F = Force
A	→	A = Area

NOTE: Measure an actual 14ml cylinder and find the area of its piston (do not measure the drawing on this paper or use the example area value).

Show your work below:

Answer:

The Air Pressure inside the cylinder = 71.4psi (lbs/in²)

Finger over tip so no air escapes.

Answer:

PNEUMATIC PLAY

You will need a 14ml-14ml pneumatic system for this section.
Refer to the end of the lab for assistance assembling.

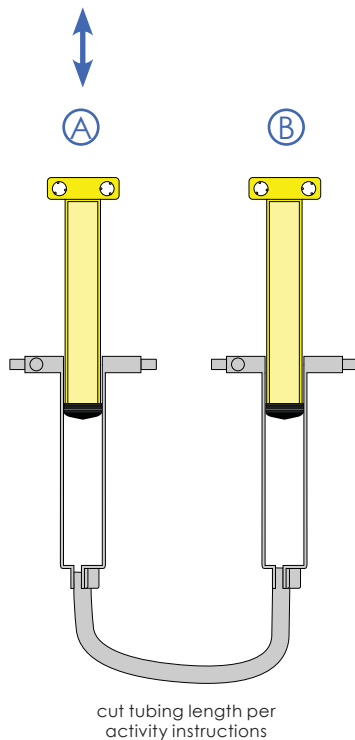

TIP use colored water in hydraulic systems

Push One Piston

Push and pull piston **A**. Examine what happens and answer all the questions below.

Complete the following sentences using some of these words (words can only be used once):

faster liquid slower
 inversely transfers gas force
 fluid solid

11. The pistons move inversely to each other.

12. Piston **B** moves slower than piston **A** (the piston you pushed and pulled) due to air compressing.

13. The pressure applied by piston **A** transfers through the fluid (air) to piston **B**, applying a force that causes piston **B** to move.

PNEUMATIC PLAY

Use the same 14ml-14ml pneumatic system as before.

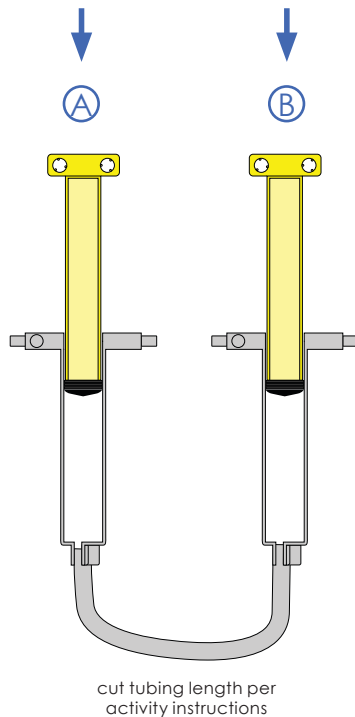

Push Both Pistons

Push and pull **both** pistons. Examine what happens and answer all the questions below.

Complete the following sentences using some of these words (words can only be used once):

pressure force psi potential

compresses kinetic

14. An external is needed to move the pistons into the cylinders.
15. The pressure applied by the pistons the air in the cylinders and line.
16. means the same thing as lbs/in².
17. Compressed air has (stored) energy.
18. After pushing both pistons in, quickly let go of one piston. The piston you let go moves outward with energy.

SHARING PRESSURE & FLUID

How does fluid pressure transfer between cylinders? How can a force applied to one piston cause the other piston to move? Fill in the boxes below to find out.

Piston C Applies Pressure

19. Complete the formula to find the pressure applied by piston C:

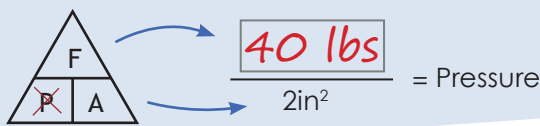

20. Pressure inside chamber C = psi

Fluid Transfers the Pressure

21. Pressure is transmitted from chamber C through line to chamber .

22. Pressure inside chamber H = psi

Piston D Turns Pressure into Force

23. The fluid pressure applied to piston D = psi

24. Complete the formula to find the force of piston D:

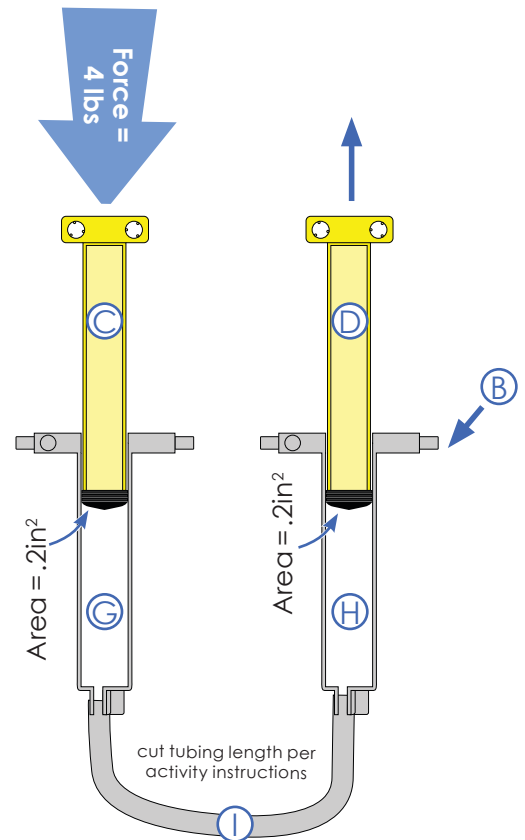
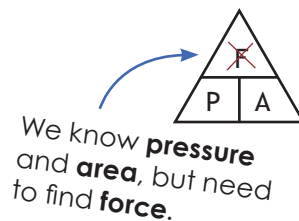

$$\text{Force} = \text{Pressure} \cdot \text{Area}$$

$$\text{Force} = \text{20 psi} \cdot 2\text{in}^2$$

$$\text{Force of Piston} = \text{40 lbs}$$

Master & Slave Cylinders

25. The cylinders above can be referred to as a **master cylinder** and **slave cylinder**. Why do you think cylinder B is referred to as the slave cylinder?

The master cylinder controls the slave cylinder.

FRICTION

Friction is a force that opposes the motion of an object, when the object is in contact with another object or surface. It turns some of the object's kinetic energy into **heat**.

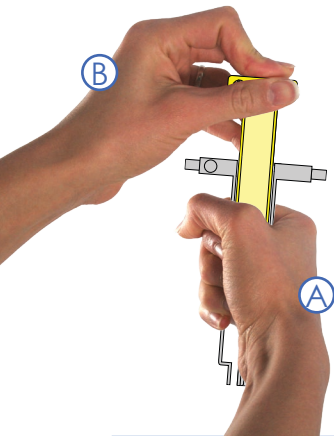

- Ⓐ Grip the cylinder.
- Ⓑ Push and pull the piston 30 times, as fast as you can.

26. What happens to the cylinder as you move the piston? Why does this happen?

It becomes warm from the friction between the piston and cylinder wall.

When liquid flows in a hydraulic circuit, friction produces heat (*wasted energy*).

How can you reduce friction in your hydraulic system?

- Shorten the lines
- Reduce bends in the line
- Properly size the line

27. Draw a line that would highly resist the flow of fluid between cylinders:

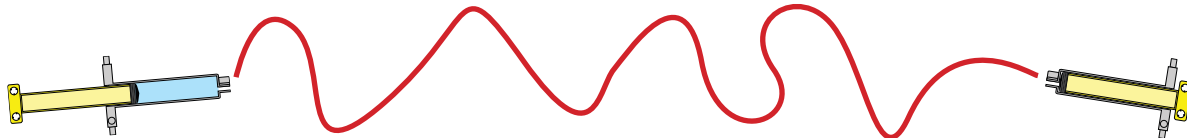

the line should be long and bend

VISCOSITY

Viscosity: a measure of a fluid's resistance to being deformed. Viscosity is a fluid's resistance to flowing. It can also be called its thickness.



water is *thin*
has **low viscosity**



ketchup is *thick*
has **high viscosity**

28. Write the following words in the boxes below in order of least viscous to most viscous: **Milk, Honey, Air, Peanut Butter**

Least Viscous

air

milk

honey

peanut butter

Most Viscous

NON-NEWTONIAN FLUIDS

Fluids without a constant viscosity are called "**Non-Newtonian**" fluids. You can experience a Non-Newtonian fluid, here's how:

Mix two cups cornstarch with one cup water.



A fluid that changes viscosity depending on the pressure applied to it.

BONUS POINTS

Find a new use (good use) for a **Non-Newtonian** fluid. Present it to your class.

points: _____

HYDRAULICS

Now we will use a **liquid** to transmit power between cylinders. For the remainder of the lab, you will need 14ml-14ml and 4.5ml-14ml hydraulic systems. Refer to the end of the lab for help.

Hydraulic Book Work

Create the mechanism shown. Pushing piston **A** should lift the book.

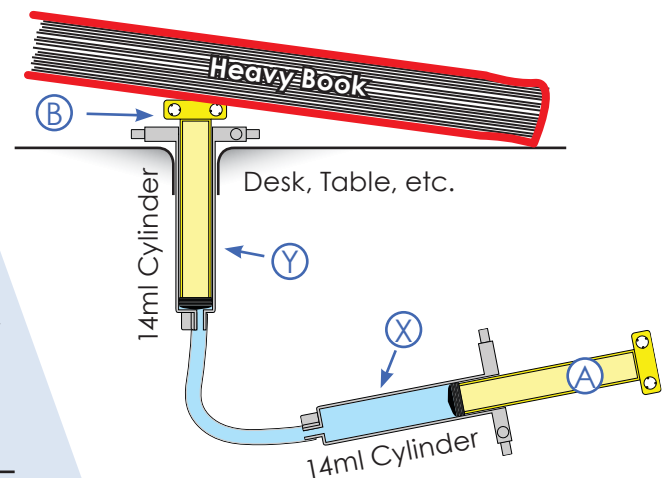

29. Show your teacher the completed mechanism. Explain how it changes force to pressure, transfers the pressure, and then changes it back to force.

Teacher Signature _____

30. Push in piston **A** 5cm, piston **B** moves ~5cm cm out of cylinder **Y**.

31. Pull back piston **A** 5cm, piston **B** moves ~5cm cm into cylinder **Y**.

32. Pneumatic fluid is highly **compressible**. How compressible is hydraulic fluid?
Hydraulic fluid is not very compressible (it appears not to compress).

33. When you push piston **A**, piston **B** moves immediately. How is that different than the pneumatic system you previously used?
At first the pneumatic system compressed the air, rather than immediately moving the cylinder

Bubbles are Bad

34. Why is it bad to have air bubbles in a hydraulic system?

- A** Air bubbles will not compress, but hydraulic fluid will.
- B** The air in the system will expand or contract, causing the system to become delayed and transfer less pressure.
- C** You can giggle and say that it "has gas".

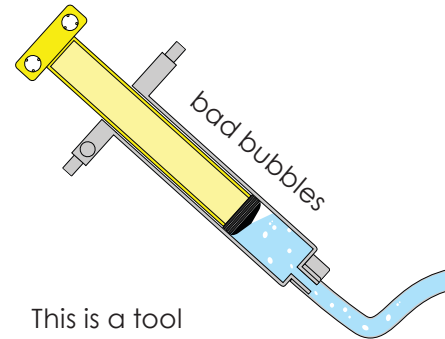

This is a tool for **bleeding** (removing the air from) brake lines on cars.

WORK

The scientific definition of **work**: using a force to move an object a distance.

$$\text{Work} = \text{Force} \cdot \text{Distance}$$

The **force** is the pull or the push on an object, resulting in its movement.

The **distance** over which the output force is applied.



Forklifts use hydraulics to perform work (moving loads).

Work on Work

35. If schools used the scientific definition for **work**, what would homework be?

Homework would be moving things.

36. The diagram on the right shows cylinders that have lifted weights.

Place an under the cylinder that has done the most work.

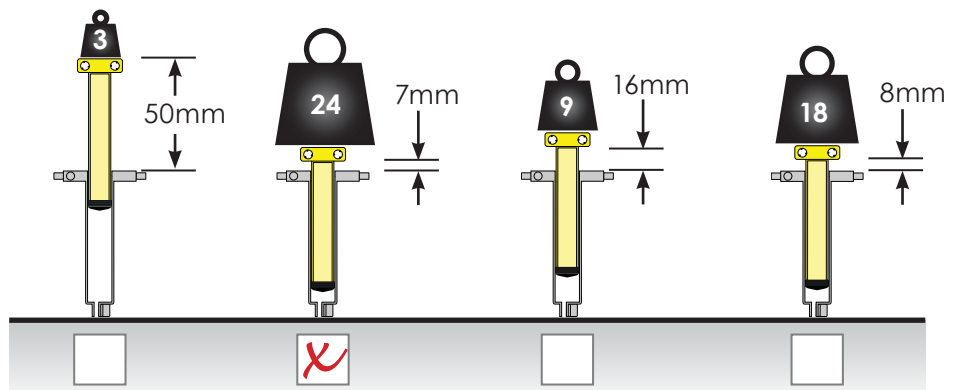

MECHANICAL ADVANTAGE

Mechanical Advantage is the relationship between the work going into a system, and work coming out of a system.

IMA vs. AMA

Some energy will be lost by a machine (mostly through **friction**).

Ideal Mechanical Advantage (IMA) does not account for any energy lost.

$$\text{Work}_{in} = \text{Work}_{out} \text{ with IMA}$$

Actual Mechanical Advantage (AMA) accounts for energy lost.

$$\text{Work}_{out} < \text{Work}_{in} \text{ with AMA}$$

A nutcracker allows you to apply a force larger than you could with your bare hand.

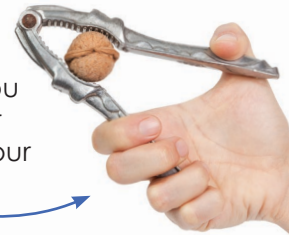

<p>smaller force applied over a larger distance:</p> $\text{Force}_{in} \cdot \text{Distance}_{in}$ $10\text{lbs} \cdot 1\text{in}$ $= 10\text{in-lbs}$	<p>=</p>	<p>larger force applied over a smaller distance:</p> $\text{Force}_{out} \cdot \text{Distance}_{out}$ $40\text{lbs} \cdot .25\text{in}$ $= 10\text{in-lbs}$
---	----------	---

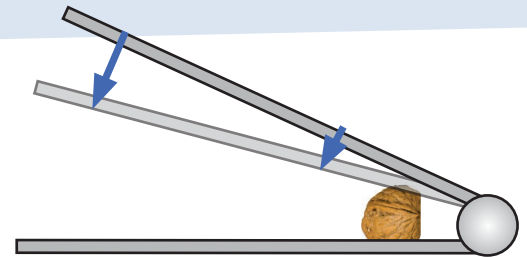

Nutcracker Cracking a Nut

Ideal Mechanical Advantage

$$\text{Work} = \text{Force} \cdot \text{Distance}$$

$$\text{Work}_{in} = \text{Work}_{out}$$

$$\text{Force}_{in} \cdot \text{Distance}_{in} = \text{Force}_{out} \cdot \text{Distance}_{out}$$

↑	↓	↑	↓
Input Force "Effort"	The distance over which the input force is applied	Output Force "Load"	The distance over which the output force is applied

Work_{out}

This large cylinder moves a small distance with great force.



Work_{in}

This small cylinder is repeatedly moved up and down (a large distance) with little force.

37. Calculate the **output force**:

$$\text{Force}_{in} \cdot \text{Distance}_{in} = \text{Force}_{out} \cdot \text{Distance}_{out}$$

$$250\text{lbs} \quad 25\text{in} \quad \boxed{625 \text{ lbs}} \quad 10\text{in}$$

Ideal Mechanical Advantage

Divide the **Distance_{in}** by the **Distance_{out}** or the **Force_{out}** by the **Force_{in}** to find the mechanical advantage.

$$\text{Force}_{in} \cdot \text{Distance}_{in} = \text{Force}_{out} \cdot \text{Distance}_{out}$$

can be rearranged as

$$\text{Ideal Mechanical Advantage} = \frac{\text{Distance}_{in}}{\text{Distance}_{out}} = \frac{\text{Force}_{out}}{\text{Force}_{in}}$$

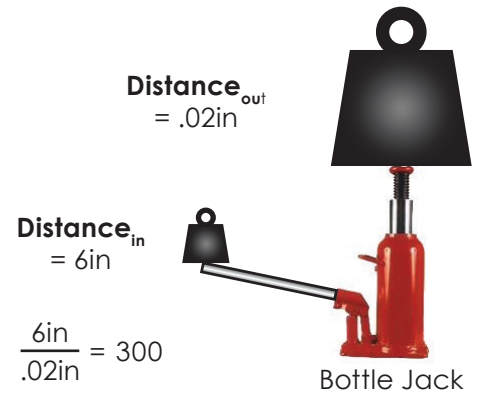

The ideal mechanical advantage of the jack can be represented as:

"300" or "300:1" or "300 to 1"

38. Calculate the Force_{out}: Show your work.

$$\text{Force}_{in} = 23\text{lbs}$$

$$\text{Ideal Mechanical Advantage} = 55$$

$$\text{Force}_{out} = \boxed{1265 \text{ lbs}}$$

Distance for Force

Set up the 4.5ml-14ml hydraulic system, as shown, so it will lift a book. Experiment with it and answer the questions below.

39. If piston (A) moves 1 inch, piston (B) moves: $\boxed{.35in}$

40. Complete the following formula to find the force at piston (B) (**Force_{out}**).

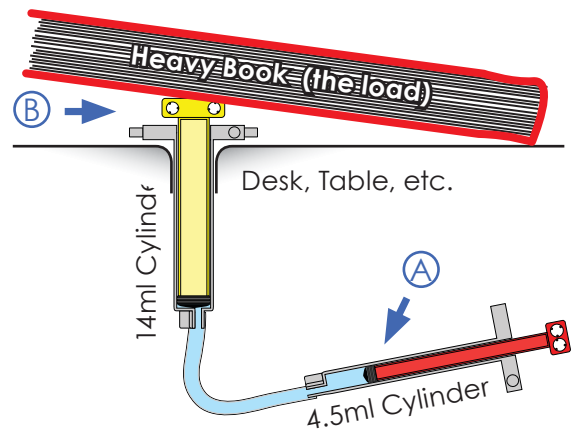

$$\text{Ideal Mechanical Advantage} \rightarrow \frac{\text{Distance}_{in}}{\text{Distance}_{out}} = \frac{\text{Force}_{out}}{\text{Force}_{in}} \rightarrow \frac{1in}{\boxed{.35in}} = \frac{\boxed{17.14lbs}}{6lbs}$$

Calculate the Force_{out} by cross multiplying.

41. Mechanical Advantage = $\boxed{2.86}$

Force the Distance

Set up the 4.5ml-14ml hydraulic system, as shown, so it will lift a book. Experiment with it and answer the questions below.

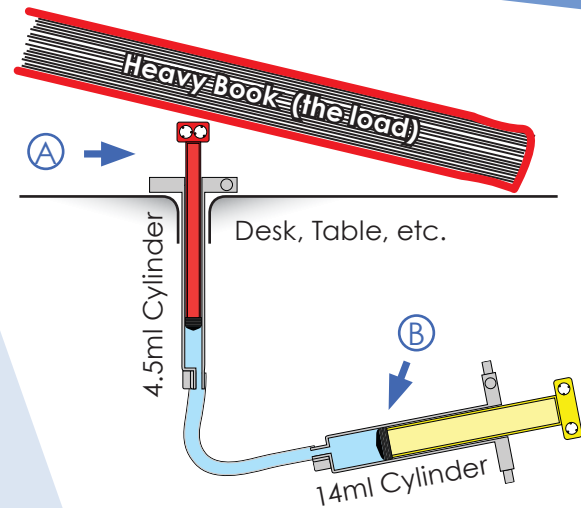

42. If piston (B) moves 1 inch, piston (A) moves: 1.42in

43. Complete the following formula to find the force at piston (A) (**Force_{out}**).

Calculate the Force_{out} by cross multiplying.

$$\text{Ideal Mechanical Advantage} \rightarrow \frac{\text{Distance}_{in}}{\text{Distance}_{out}} = \frac{\text{Force}_{out}}{\text{Force}_{in}} \rightarrow \frac{1in}{1.42in} = \frac{2.11lbs}{6lbs}$$

44. Mechanical Advantage = .35

Calculate by dividing the Force_{out} by the Force_{in} or the Distance_{in} by the Distance_{out}

HINT: This number should be less than one because this system **loses** force to **gain** distance.

HYDRAULIC CYLINDERS = A LEVER

Two connected hydraulic cylinders act like a lever, changing the **force**, **distance**, and direction of **movement**.

45. Label the **Force_{in}** and the **Force_{out}** on the cylinders below to show a mechanical advantage similar to the lever.

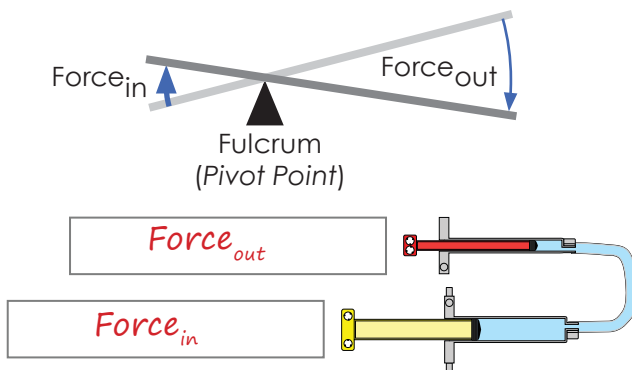

46. Label the **Force_{in}** and the **Force_{out}** on the cylinders below to show a mechanical advantage similar to the lever.

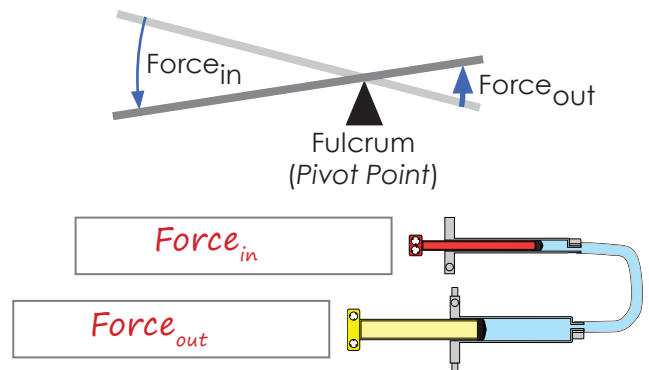

HOW DOES MECHANICAL ADVANTAGE DEVELOP?

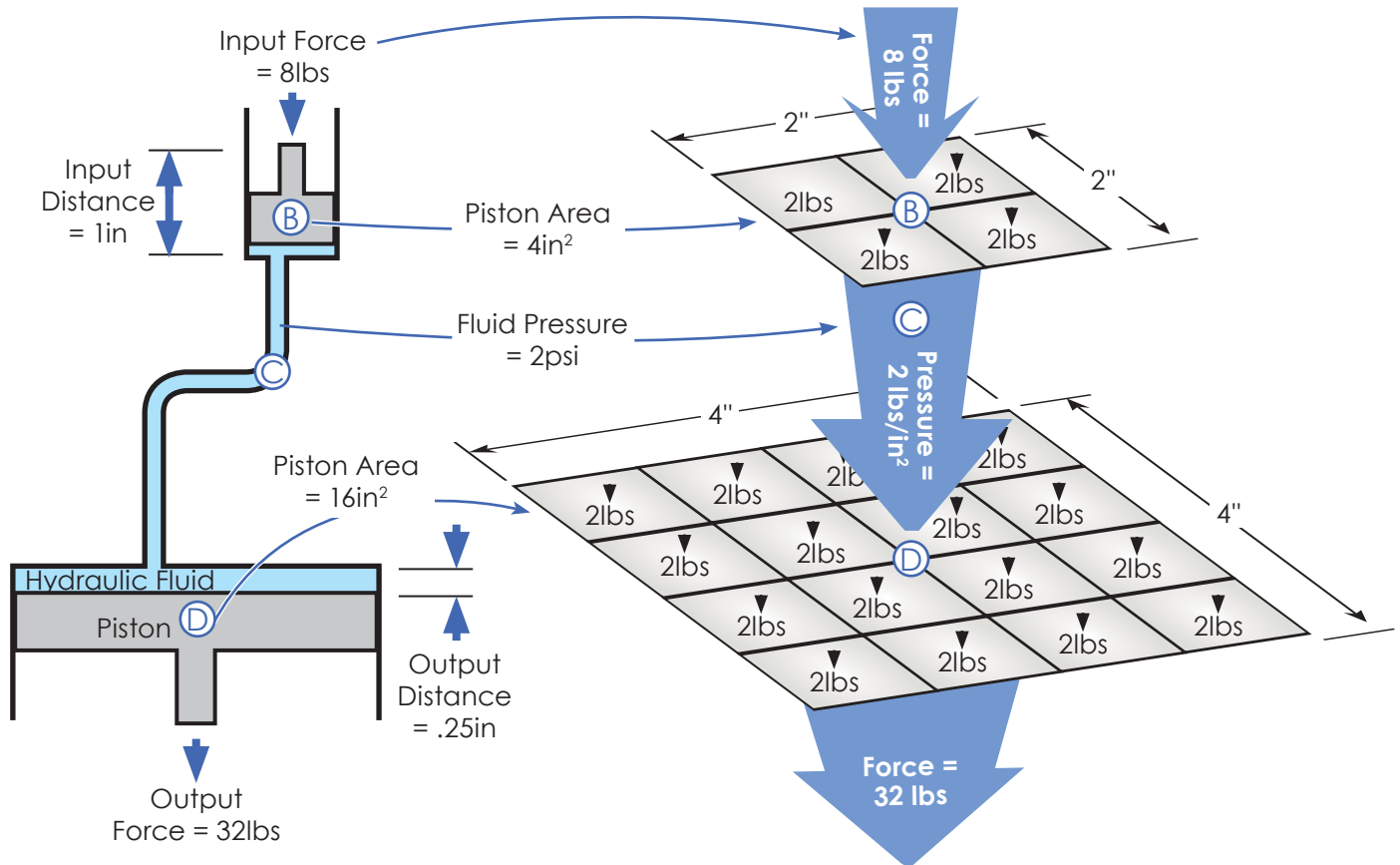

- 1 8lbs of force is applied to piston (B).
- 2 The 8lbs of force is divided over the area of piston (B) and transferred to the fluid (C):

<u>Force</u>	$\frac{8\text{lbs}}{4\text{in}^2} = 2\text{lbs/in}^2$	<u>Fluid Pressure</u>
Piston's Area		
- 3 Pressure is transferred through fluid (C) (Pascal's Law) to piston (D).
- 4 Fluid (C) presses against every square inch of piston (D), creating 32lbs of force:

<u>Fluid Pressure</u>	•	<u>Area of Piston (D)</u>	=	<u>Output Force</u>
2lbs/in^2		16in^2		$= 32\text{lbs}$
- 5 Piston (D) applies a downward force of 32lbs.

NOTE: The /in² and in² cancel each other out.

YOU'RE ON YOUR OWN

TOTAL POINTS: /10

A. Find the **Force_{out}**, **Distance_{out}** and **mechanical advantage** of the hydraulic system below. Show all work.

Pressure developed from **force** applied over piston area: 2.54 in^2

$\text{Force} = 6 \text{ lbs}$

$\text{Area} = 2.54 \text{ in}^2$



$\text{Area of a circle} = \pi \cdot \text{Radius}^2$
 $3.14 \cdot .92 = 2.54 \text{ in}^2$

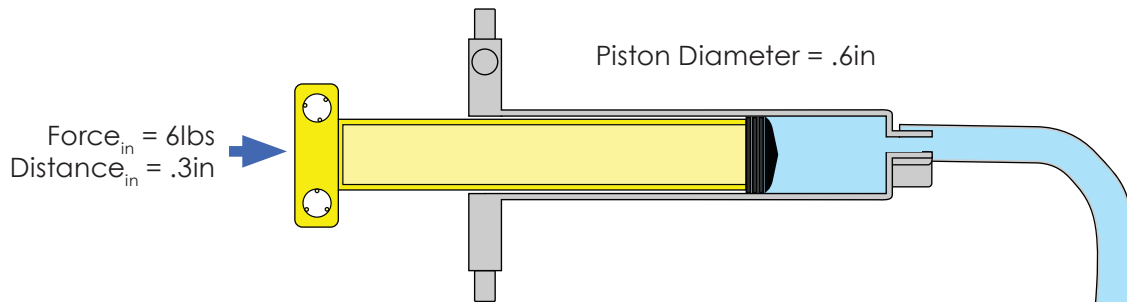

Piston force developed from **fluid pressure** over piston area:

$2.36 \text{ lbs/in}^2 \cdot .22 \text{ in}^2 = .52 \text{ lbs}$

$\text{Force}_{\text{out}} = .52 \text{ lbs}$

$\text{Distance}_{\text{out}} = 2.31 \text{ in}$

Piston Diameter = .35in



$$\frac{.2 \text{ in}}{\text{Distance}_{\text{out}}} = \frac{.52 \text{ lbs}}{6 \text{ lbs}} = \text{mechanical advantage}$$

Mechanical Advantage =

A FLUID POWERED INVENTION

B. Design and draw an invention that uses **hydraulics** or **pneumatics** to perform one of the following tasks: open a jar, crack an egg, or toss a ball.

Presentation	Is it well drawn and easy to understand?	/3
Function	Could it really work? Does it use fluid power?	/3
Creativity	Does it solve the task in a new and different way?	/4
total points:		/10

CONGRATULATIONS!!

You've finished the Fluid Power Lab.
It's time to create a fluid powered contraption.

ASSEMBLY REFERENCE SHEET

Use the tubing lengths specified for your hydraulic activity (shown on page 2).

Pneumatics

1 Have one cylinder all the way open.

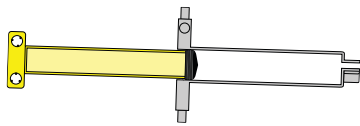

2 One cylinder all the way closed.

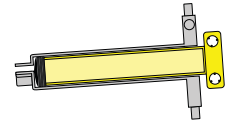

3 Connect cylinders with tubing.
(use length shown on page 2).

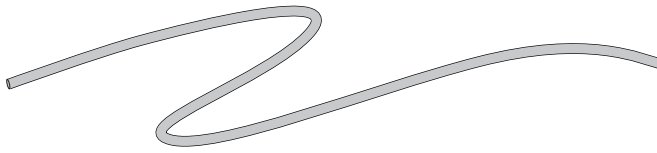

Hydraulics

1 Fill both cylinders with water:

- A Push cylinder piston in
- B Place cylinder tip underwater
- C Pull piston back to completely fill the cylinder with water

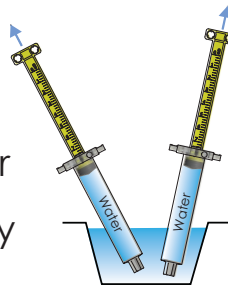

2 Attach tubing (as noted for activity) to filled cylinder.

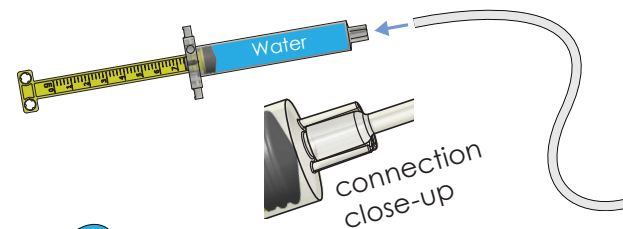

3 Fill the tubing completely with water by pushing the piston completely in.

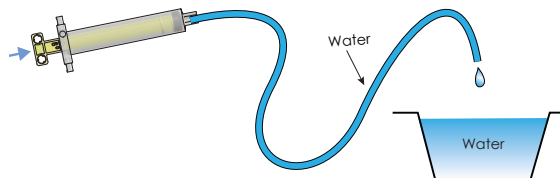

4 Attach the water-filled tubing to the remaining water-filled cylinder from Step 1.

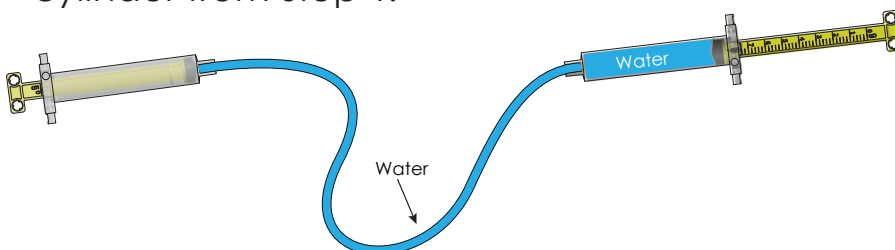

5 Insert a cylinder screw as shown to prevent the tubing from pulling off.

