

Makerspace Mobile Storage Cart 91412

demco[®]
imagine what's possible™

Find MooreCo Table Accessories @demco.com





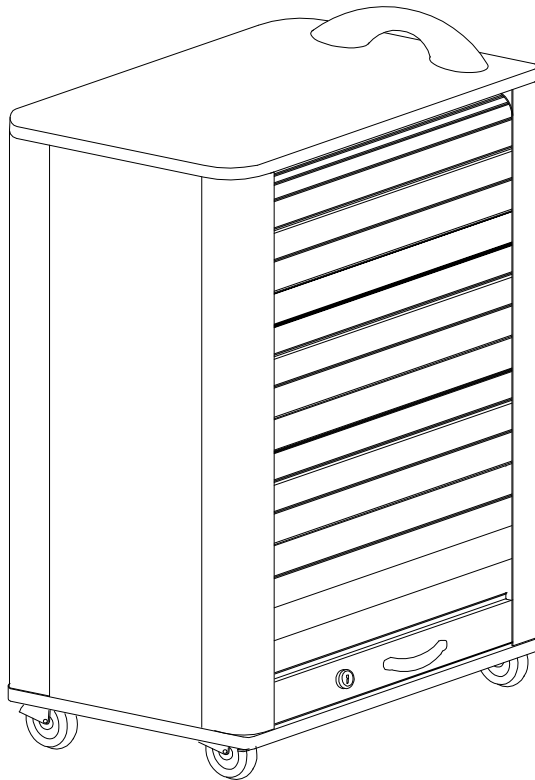





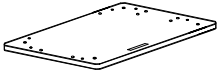
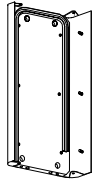

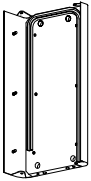

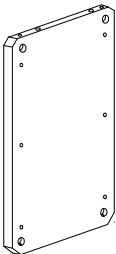

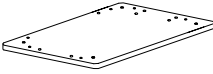

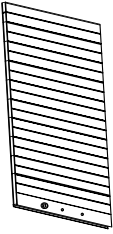

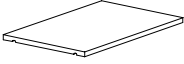
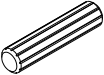
Search: *MooreCo Table Accessories*

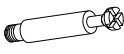
Call 800.962.4463 or email custserv@demco.com

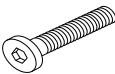
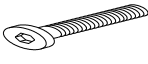

Assembly Instructions

91412 Makerspace Mobile Tub Storage Cart

Part	Drawing	Description	Qty	Part	Drawing	Description	Qty
P-1		Base	1 EA	Hardware List			
P-2		Left Side Panel	1 EA	A		Locking Caster	2 EA
P-3		Right Side Panel	1 EA	B		Non-Locking Caster	2 EA
P-4		Back Panel	1 EA	C		Large Handle	1 EA
P-5		Top Panel	1 EA	D		Small Handle	1 EA
P-6		Door Assembly	1 EA	E		Allen Wrench	1 EA
P-7		Shelves	4 EA	F		Wood Dowels	12 EA
				G		Cam Lock	12 EA
				H		Cam Post	12 EA
				I		Keys	Set
				J		Shelf Pins	16 EA
				K		Tapped Rivet	10 EA
				L		Screws M6*18mm	16 EA
				M		Screws M6*25mm	4 EA
				N		Screws M6*30mm (Large Handle)	2 EA
				O		Screws M3*20mm	2 EA
				O1		Washer	2 EA
				P		Bumper	2 EA
				Q		Screw 30mm(Bumper)	2 EA

Assembly Diagram

READ THROUGH INSTRUCTIONS FROM BEGINNING TO END BEFORE STARTING TO ASSEMBLE UNIT.

1.) Identify and Separate all the Parts and Hardware.

2.) Screw on two Locking Casters (A) into the front embedded threaded inserts in the bottom of the Base (P-1) using three Screws (L) as shown in Illustration # 1. Tighten Screws with Allen Wrench (E).

3.) Screw on two Non-Locking Casters (B) into the rear embedded threaded inserts in the bottom of the Base (P-1) using three Screws (L) as shown in Illustration # 1. Tighten Screws with Allen Wrench (E).

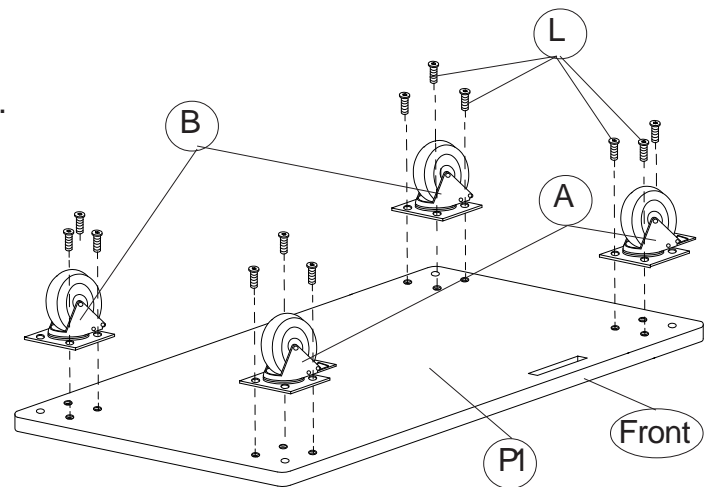

Illustration # 1

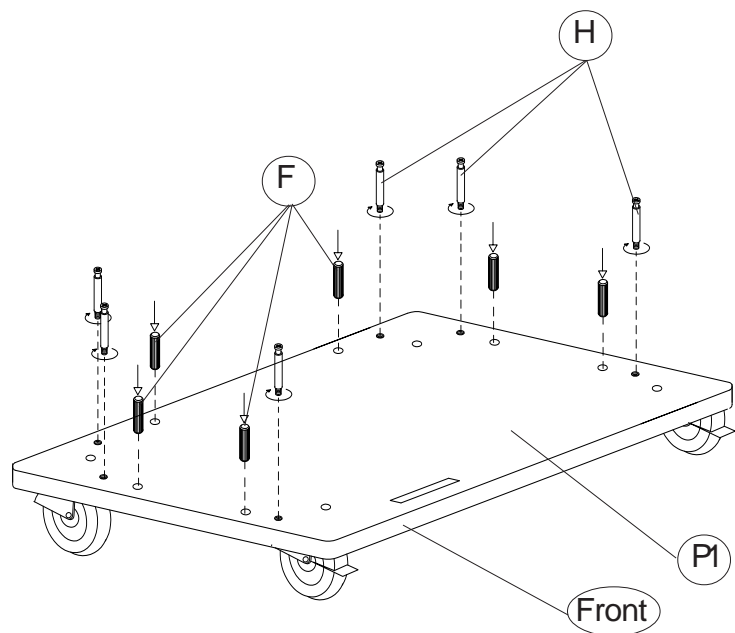

Illustration # 2

4.) Push in six Wood Dowels (F) into the predrilled holes in the top of the Base (P1) as shown in Illustration #2. Screw six Cam Posts (H) into the embedded threaded inserts in the top of the Base.

Set the completed Base to the side at this time.

- 5.) Push in six Wood Dowels (F) into the predrilled holes in the bottom of the Top Panel (P5) as shown in Illustration #3. Screw six Cam Posts (H) into the embedded threaded inserts in the bottom of the Top.

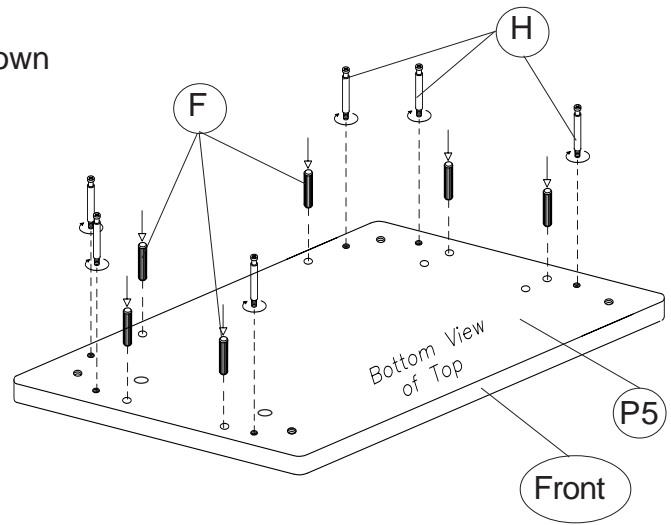

Illustration # 3

- 6.) Push in two Cams (G) into the large holes in the Back Panel (P4), the Left Side Panel (P2) and the Right Side Panel (P3) as shown in Illustration #4. Make sure the Arrows on the face of the Cams are showing and pointed down.

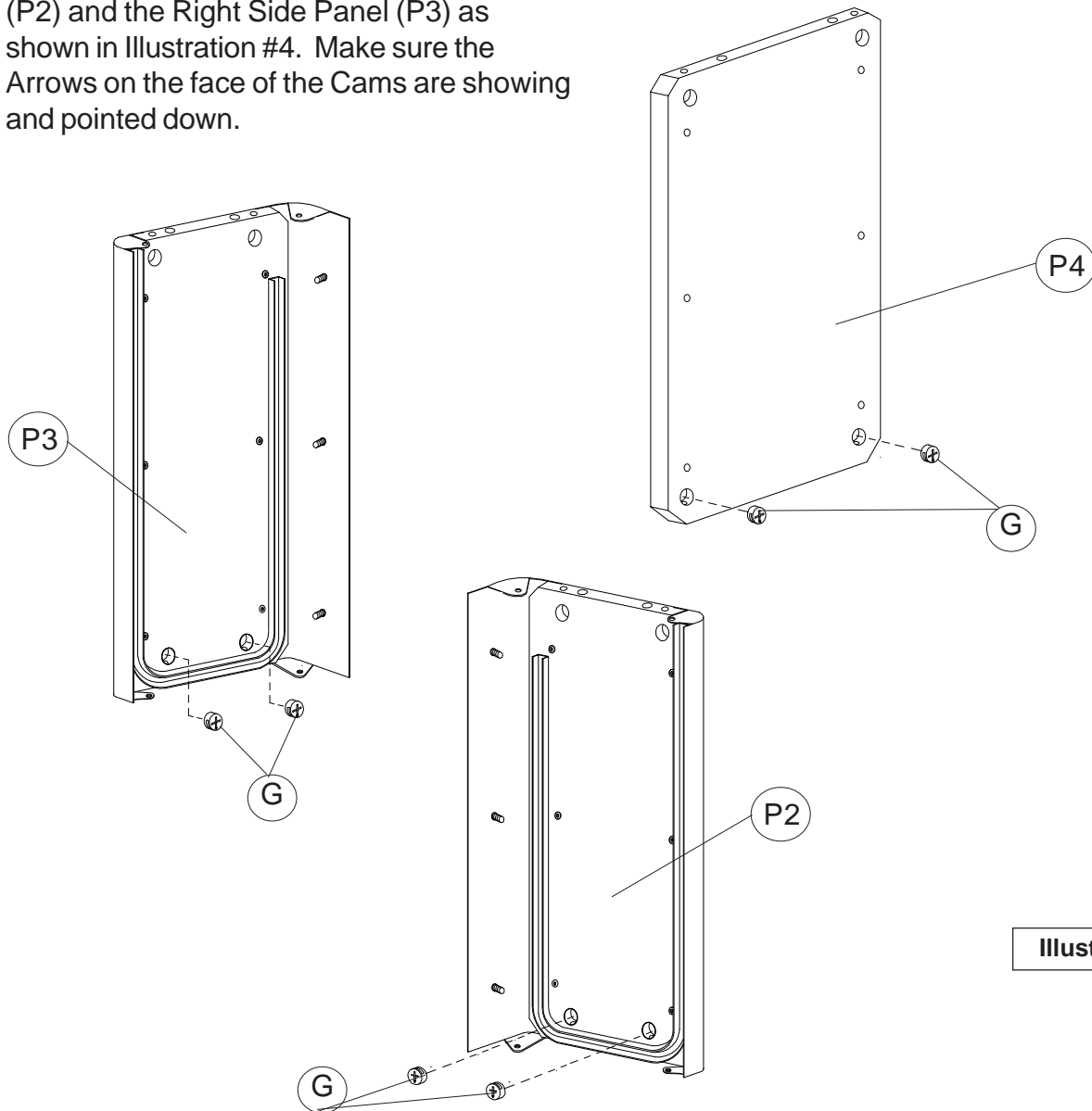
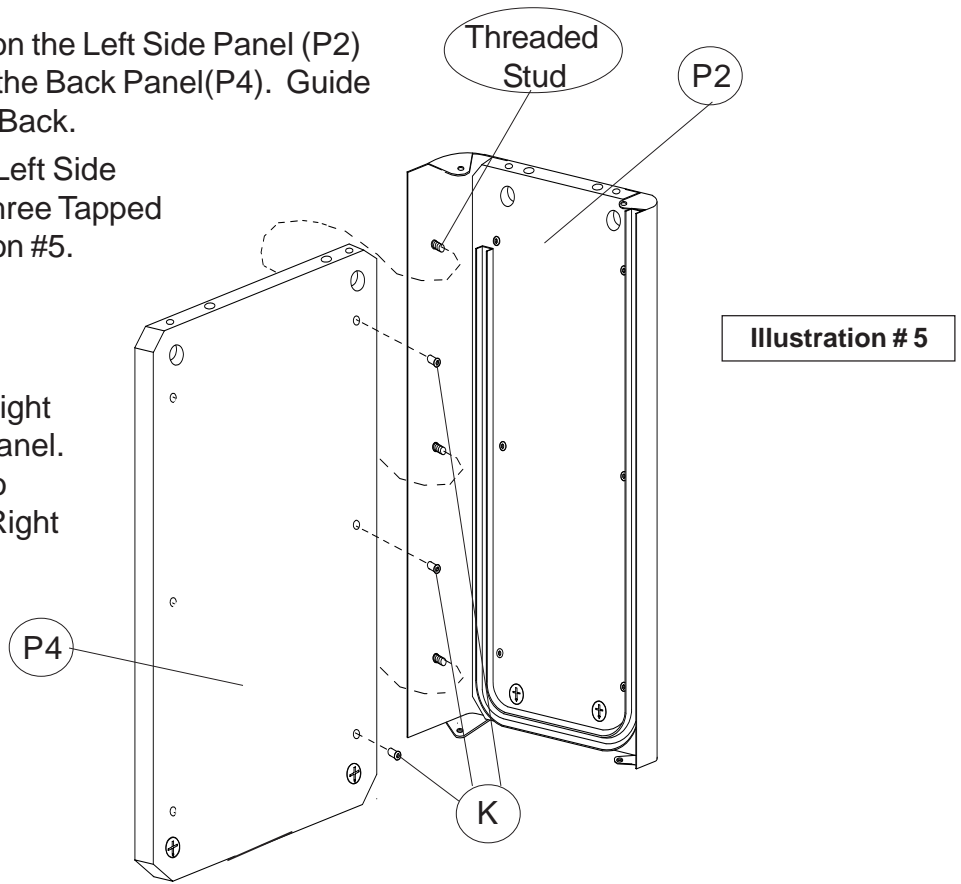

Illustration # 4

- 7.) Get the three Threaded Studs on the Left Side Panel (P2) lined up with the three holes in the Back Panel (P4). Guide the Left Side Panel in from the Back.

Secure the Back Panel to the Left Side Panel's threaded studs using three Tapped Rivets (K) as shown in Illustration #5.



- 8.) Repeat Step #7 to install the Right Side Panel (P3) to the Back Panel. Use three Tapped Rivets (K) to secure the Back Panel to the Right Side Panel.

- 9.) Lower the Back and Side Panel assembly down onto the rear Dowels and Cam Posts of the Top Panel assembly from Step #5. Turn the Cams (G) a quarter turn clockwise to lock the Back, Right Side and Left Side Panels to the Top.

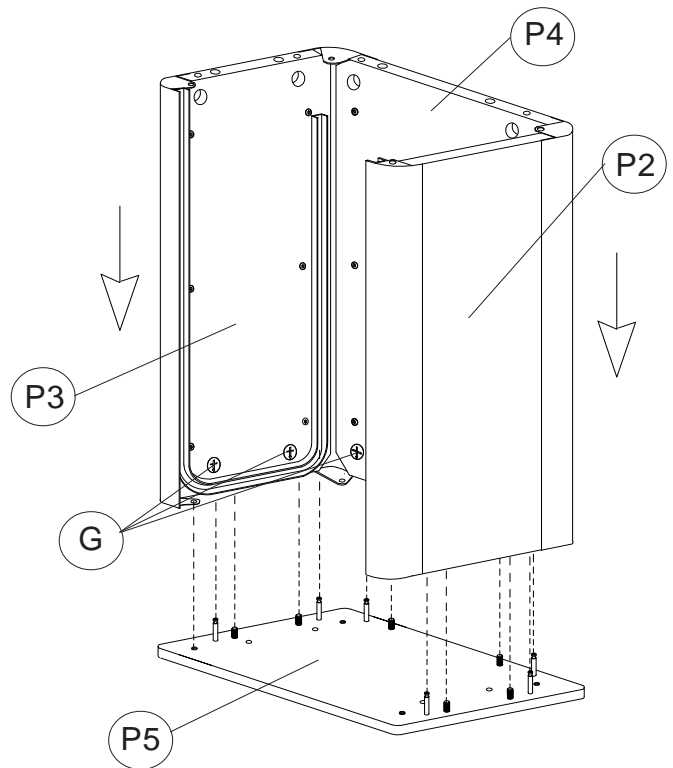

- 10.) Attach the Corner Tabs on the Left Side Panel and the Right Side Panel to the bottom of the Top Panel using one Screw (L) through the Tabs and into the embedded Threaded Inserts in the Top. See Illustration # 7.

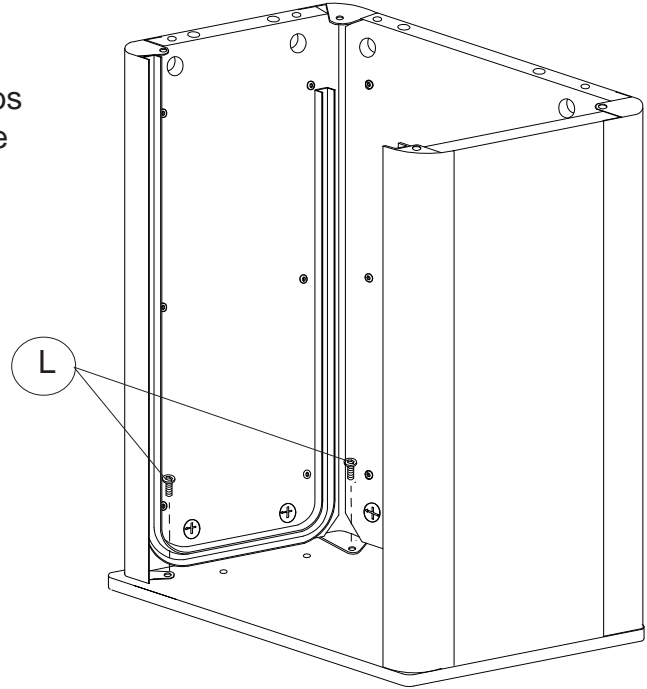

Illustration # 7

- 11.) Attach the Large Handle (C) to the Top Panel (P5) using two Screws (N).

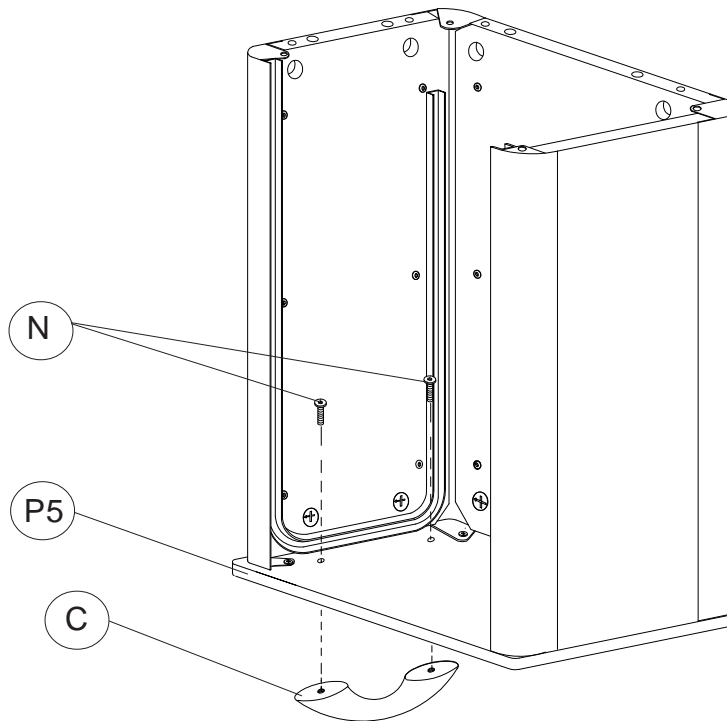
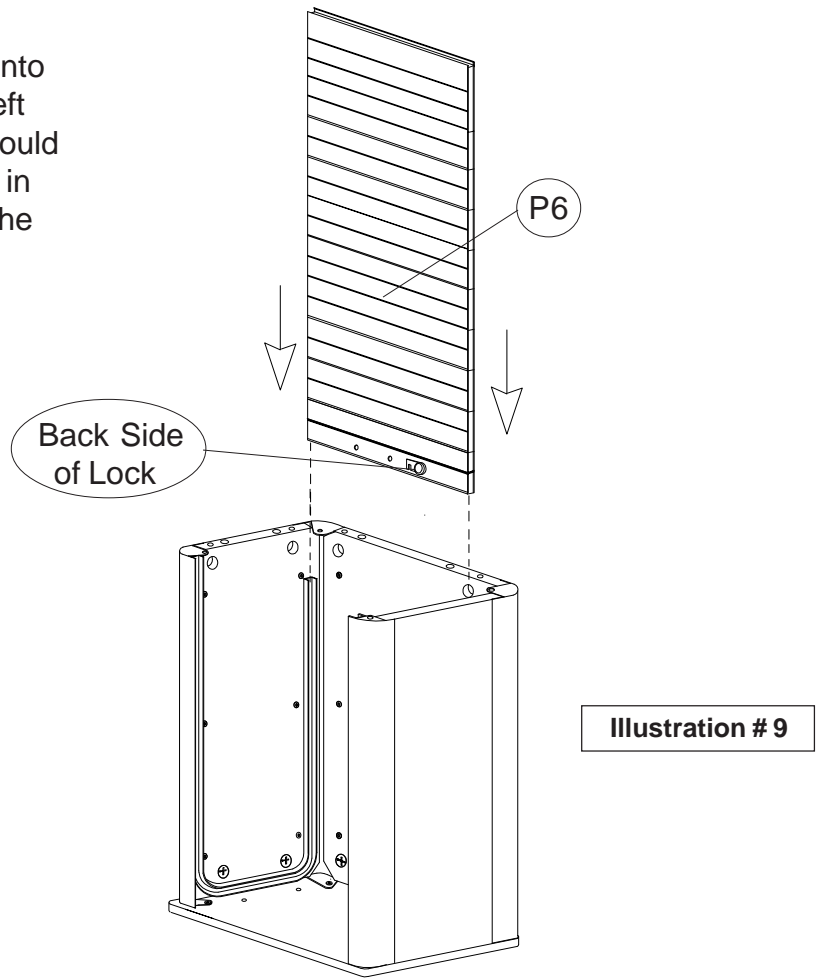
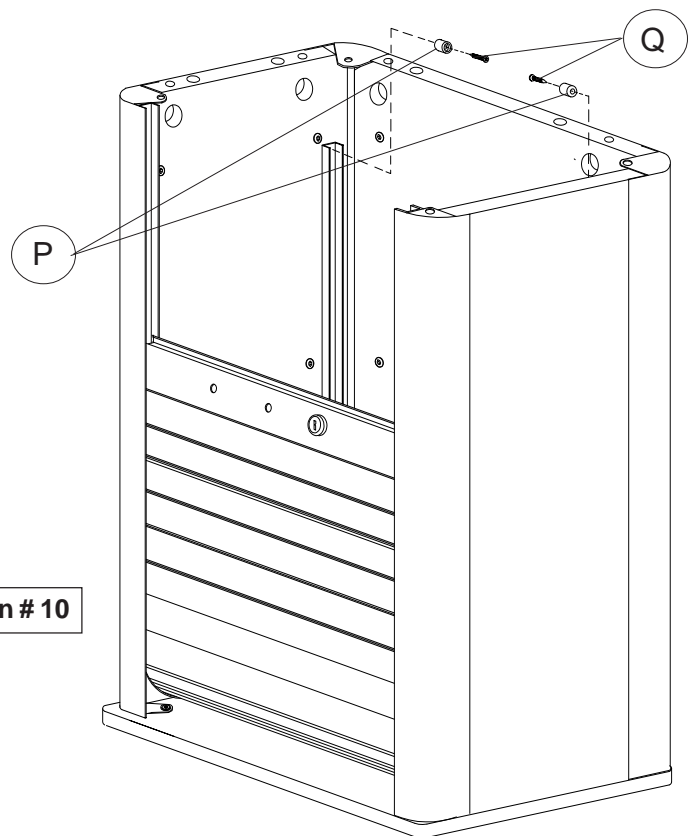

Illustration # 8

- 12.) Slide the Door Assembly (P6) down into the the rear tracks in the Right and Left Side Panels. The Door Assembly should be inserted as shown so the Key slot in the lock is at the front and bottom of the unit. See Illustration #9.



- 13.) Use one Phillips Wood Screw (Q) to attach one Bumper (P) to the bottom of each door track on the Right and Left Side Panels. These Bumpers prevent the Door Assembly from coming out of the tracks.



- 14.) Install six Cams (G) into the large holes in the Back, Right and Left Side Panels as shown in Illustration #11. Make sure the Arrows on the Cams are all pointing UP.

Illustration # 11

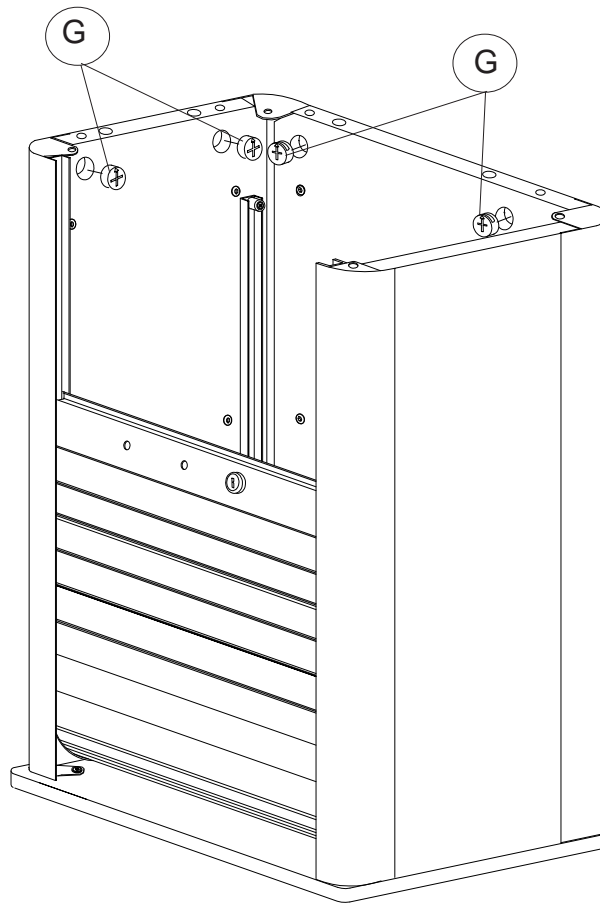

- 15.) Line up the Wood Dowels and Cam Posts in the Base Assembly from Step #4 with the holes in the ends of the Back, Right and Left Side panels. Lower the Base in place and turn the Cams a quarter turn clockwise to lock the Base in Place as shown in Illustration #12.

Illustration # 12

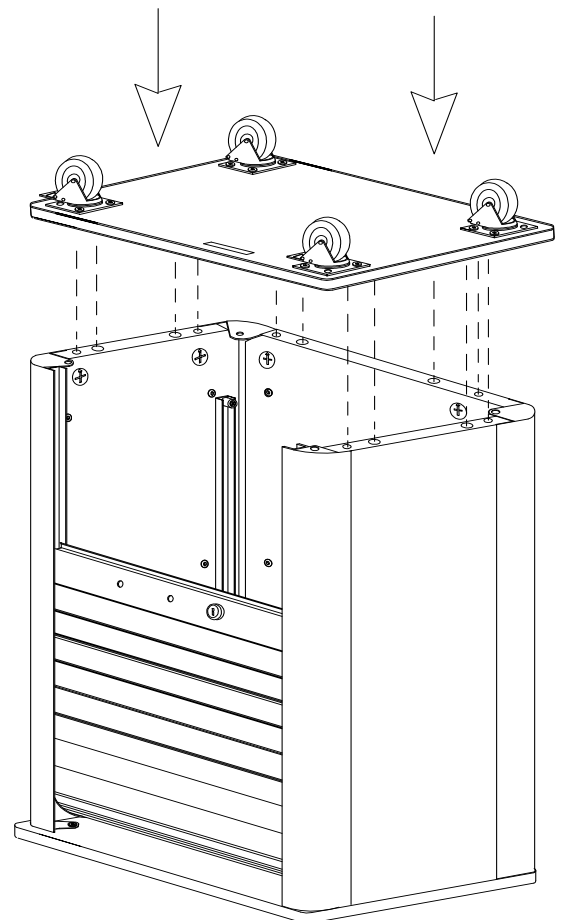

- 16.) Use four Screws (M) through the brackets in the corners of the Sides and Back, through the Base and through the Caster plate and into four Tapped Rivets (K). See Illustration #13.

Illustration # 13

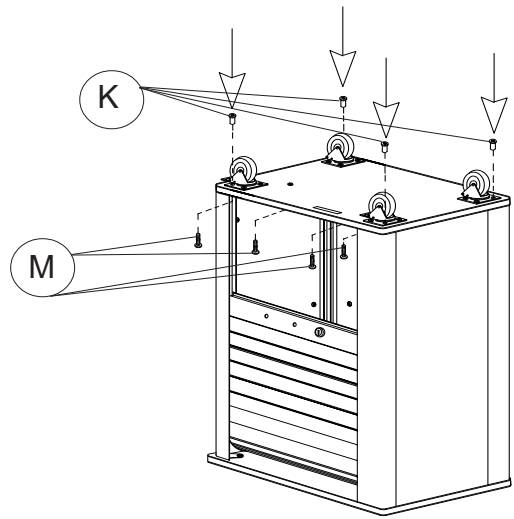

- 17.) Attach the Small Handle (D) to the bottom of the Door Assembly (P6) using two Screws (O) and two Washers (O1) as shown in Illustration #14.

Illustration # 14

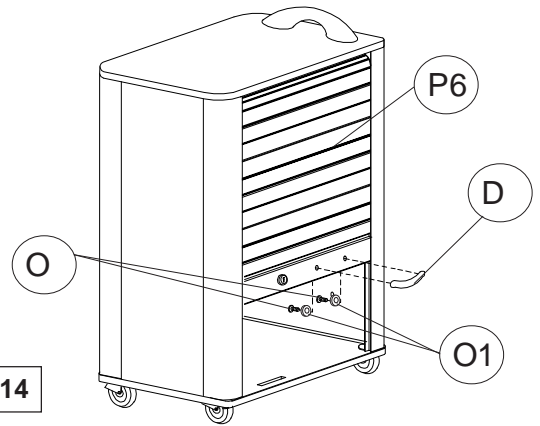

- 18.) Push in eight Shelf Pins (J) in the predrilled holes in the Left and Right Side Panels as shown.

Illustration # 15

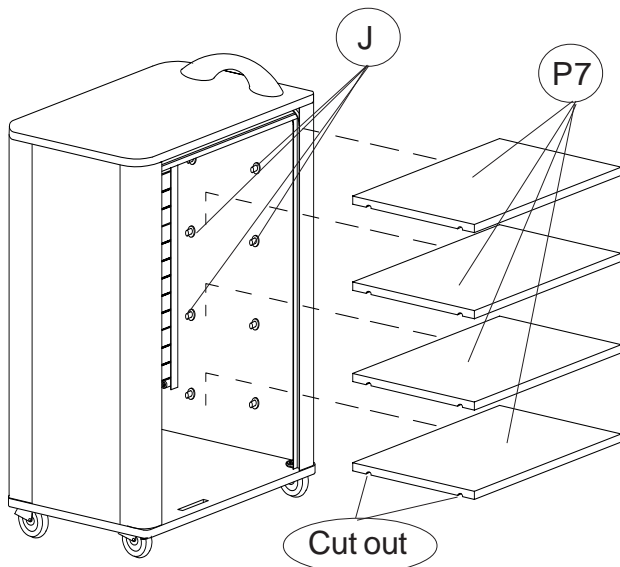
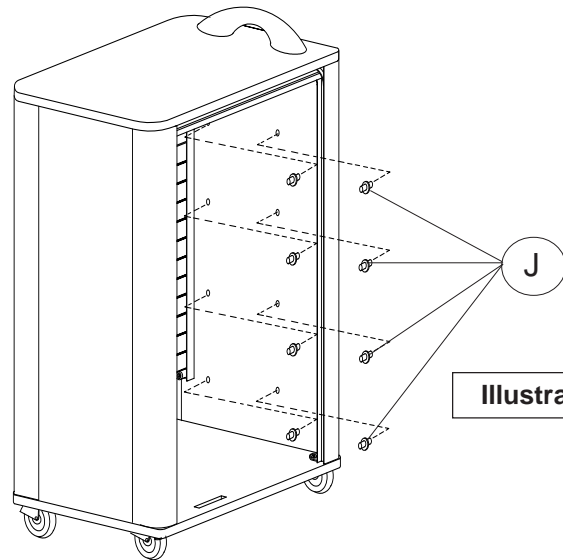
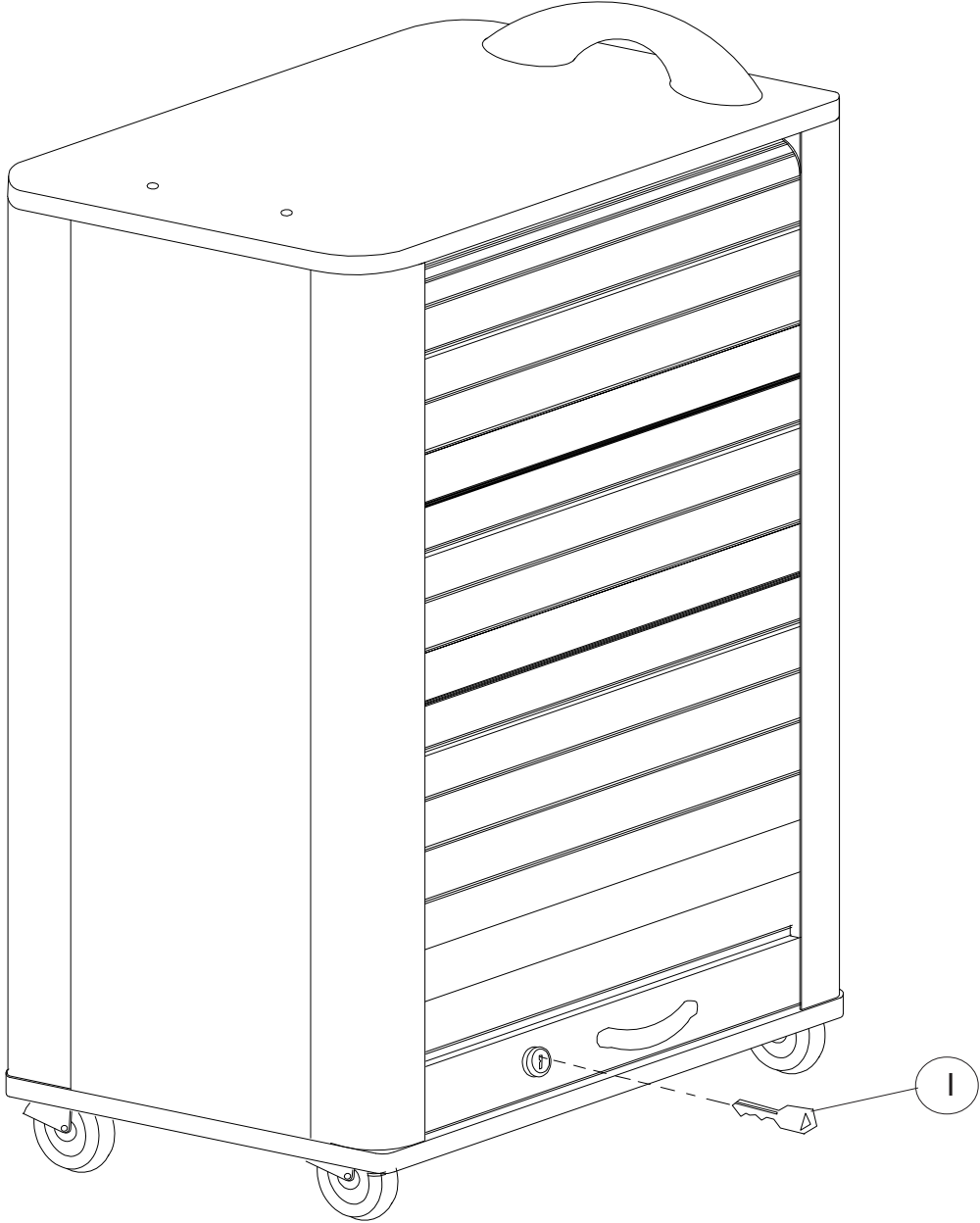

Illustration # 16

- 19.) Slide in four Shelves (P7) over the top of the Shelf Pins (J). Lower each Shelf down so the pins fit in the cut outs in the sides of the Shelves.

20.) Use Keys (I) to lock and unlock the Door Assembly (P6).



Makerspace Mobile Storage Cart 91412

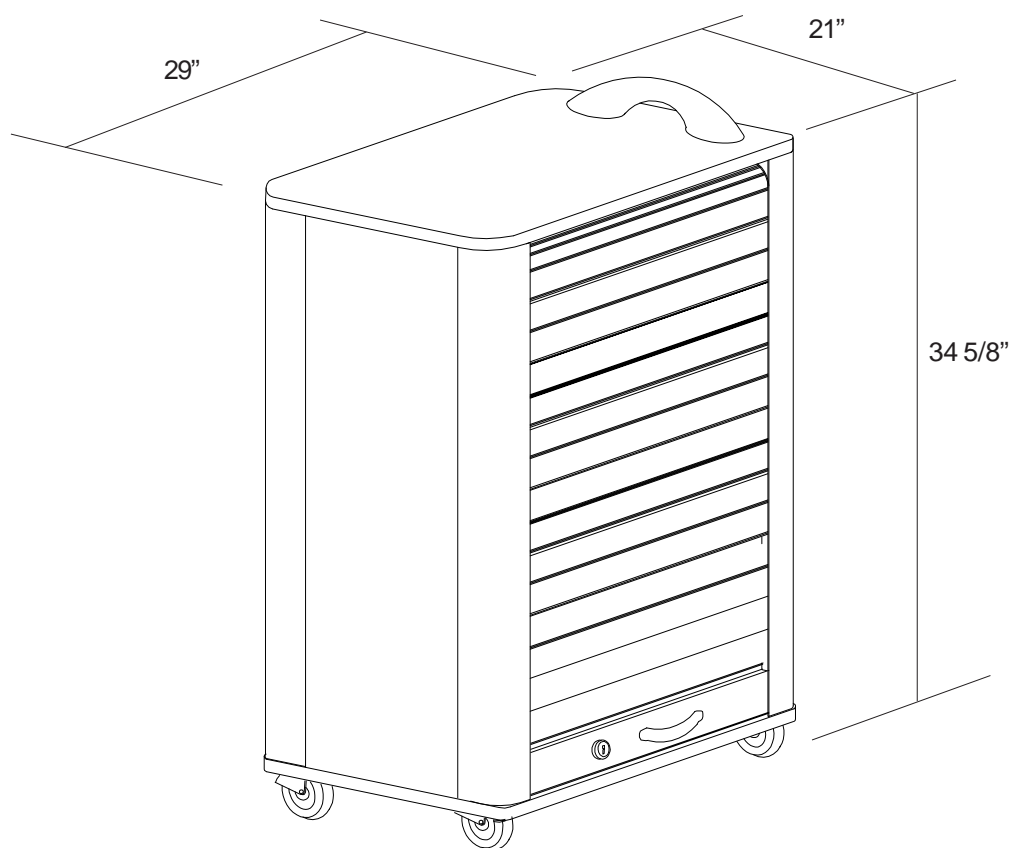

91412_04-21-17