

STANDARD TABLES - WOOD LEGS

P7, C7, & D7 SERIES TABLES (OAK OR MAPLE)
ASSEMBLY INSTRUCTIONS

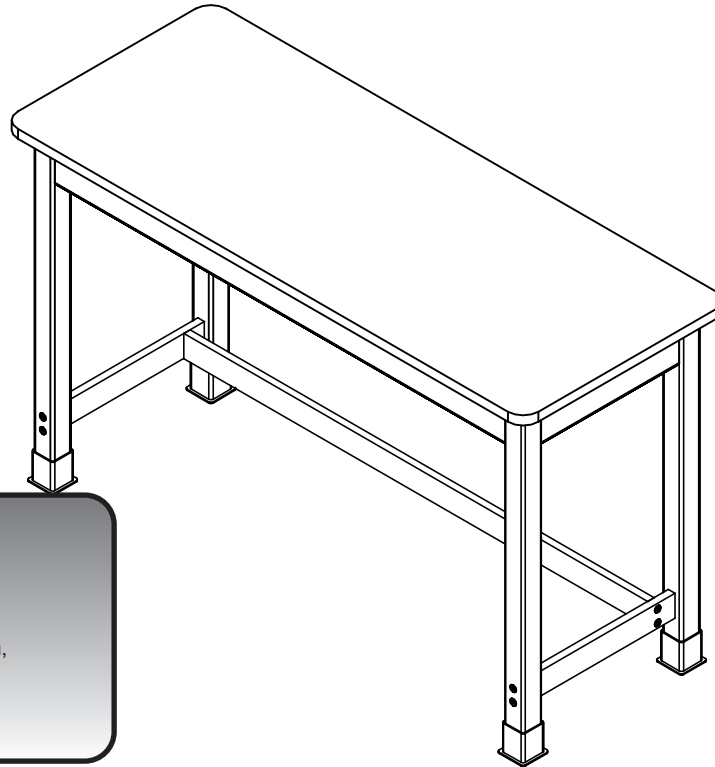



Find Diversified Spaces Science Tables @demco.com,
search **diversified spaces science tables**

Call **800.962.4463** or email **custserv@demco.com**

NOTE:

1. MODEL VIEWS MAY NOT REPRESENT EXACT MODEL PURCHASED

ALL DIMENSIONS ARE IN INCHES UNLESS NOTED OTHERWISE	DWN BY:	EMR	DATE DWN:	5/5/20
DECIMALS: $\frac{1}{16} = \pm .030$	APR BY:		DATE APR:	
$\frac{1}{8} = \pm .020$	APR BY:		DATE APR:	
$\frac{1}{4} = \pm .010$	APR BY:		DATE APR:	
ANGLES: $\pm 1^\circ$	APR BY:		DATE APR:	
CABINET SQUARENESS: $\pm .0625$	APR BY:		DATE APR:	



CONFIDENTIAL:
ALL DESIGN RIGHTS RESERVED
THE INFORMATION, DATA, DESIGN, AND DRAWINGS EMBODIED IN THIS DOCUMENT AND ALL REPRODUCTIONS THEREOF ARE THE EXCLUSIVE PROPERTY OF DIVERSIFIED WOODCRAFTS, INC.

TITLE:
**STANDARD TABLES - WOOD LEGS
ASSEMBLY INSTRUCTIONS**

THESE DOCUMENTS ARE SUPPLIED WITH THE UNDERSTANDING THAT THEY WILL NOT BE DISCLOSED TO THIRD PARTIES WITHOUT WRITTEN CONSENT OF DIVERSIFIED WOODCRAFTS, INC. ANY REPRODUCTION IN PART OR WHOLE WITHOUT WRITTEN CONSENT IS SUBJECT TO LEGAL ACTION.

DRAWING NUMBER:	SCALE:	SHEET:	REVISION:
P7, C7, & D7 SERIES TABLES	NTS	1 OF 10	REV A

A	CREATED ASSEMBLY INSTRUCTIONS	5/5/20	EMR	-
REV.	DESCRIPTION	DATE	NAME	ECN NO.

REVISION LEVEL

TOOLS REQUIRED

1/2" WRENCH OR CRESCENT WRENCH
1/2" SOCKET AND TORQUE WRENCH - OPTIONAL
4MM ALLEN WRENCH

ASSEMBLY COMPONENTS

ITEMS INCLUDED	PART #	PART DESCRIPTION	QTY
TOP AND APRON ASSEMBLY	N/A	TOP ASSEMBLY (FACTORY ASSEMBLED)	1
LEGS	VARIES	LEG, (OAK OR MAPLE) 2.25X2.25X28.25	4
LEG HARDWARE	520001-4	LEG HARDWARE KIT,4 LEGS	1
LEG BOOT	100076	LEG BOOT,BLK RUBBER	4
STRETCHER	N/A	STRETCHER - SIZE VARIES	VARIES
LEG BRACE	N/A	LEG BRACE - SIZE VARIES	2
CONFIRMATS - LEGS	227578	SCREW,7MMX90MM,CONN,ALLENHEAD, BLACK	8
CONFIRMATS - STRETCHER	228564	SCREW,7MMX50MM,CONN,ALLENHEAD, BLACK	4
SHELF - OPTIONAL	N/A	SHELF - SIZE VARIES (EITHER HALF DEPTH OR FULL DEPTH)	1
SCREWS - SHELF	100066	SCREW,#8X1.5 FSQ SMS TYPE 17	VARIES

NOTE:

1. COMPONENTS VARY WITH STYLE OF TABLE PURCHASED.
 - 1.2. TOP SELECTIONS:
 - 1.2.1. CHEMGUARD, PHENOLIC, 1 3/4" MAPLE, EPOXY, SHOPTOP, OR COLORED PLASTIC LAMINATE.
 - 1.3. SIZES OF TABLE:
 - 1.3.1. WIDTH = 48", 54", 60", & 72"; DEPTH = 21", 24", 30, 36", 42"; HEIGHT = 30", 34", OR 36".
2. **XX** INDICATES ITEMS THAT ARE ONLY USED ON MODELS WITH LEG BRACES AND STRETCHERS.

ALL DIMENSIONS ARE IN INCHES UNLESS NOTED OTHERWISE	DWN BY:	EMR	DATE DWN:	5/5/20
DECIMALS: X = ± .030 XX = ± .020 XXX = ± .010	APR BY:		DATE APR:	
ANGLES: = ± 1° CABINET SQUARENESS: = ± .0625	APR BY:		DATE APR:	



CONFIDENTIAL:
ALL DESIGN RIGHTS RESERVED
THE INFORMATION, DATA, DESIGN, AND DRAWINGS EMBODIED IN THIS DOCUMENT AND ALL REPRODUCTIONS THEREOF ARE THE EXCLUSIVE PROPERTY OF DIVERSIFIED WOODCRAFTS, INC.

TITLE:
STANDARD TABLES - WOOD LEGS
TOOLS AND ASSEMBLY COMPONENTS

THESE DOCUMENTS ARE SUPPLIED WITH THE UNDERSTANDING THAT THEY WILL NOT BE DISCLOSED TO THIRD PARTIES WITHOUT WRITTEN CONSENT OF DIVERSIFIED WOODCRAFTS, INC. ANY REPRODUCTION IN PART OR WHOLE WITHOUT WRITTEN CONSENT IS SUBJECT TO LEGAL ACTION.

DRAWING NUMBER:	SCALE:	SHEET:	REVISION:
P7, C7, & D7 SERIES TABLES	NTS	2 OF 10	REV A

A	CREATED ASSEMBLY INSTRUCTIONS	5/5/20	EMR	-
REV.	DESCRIPTION	DATE	NAME	ECN NO.

REVISION LEVEL

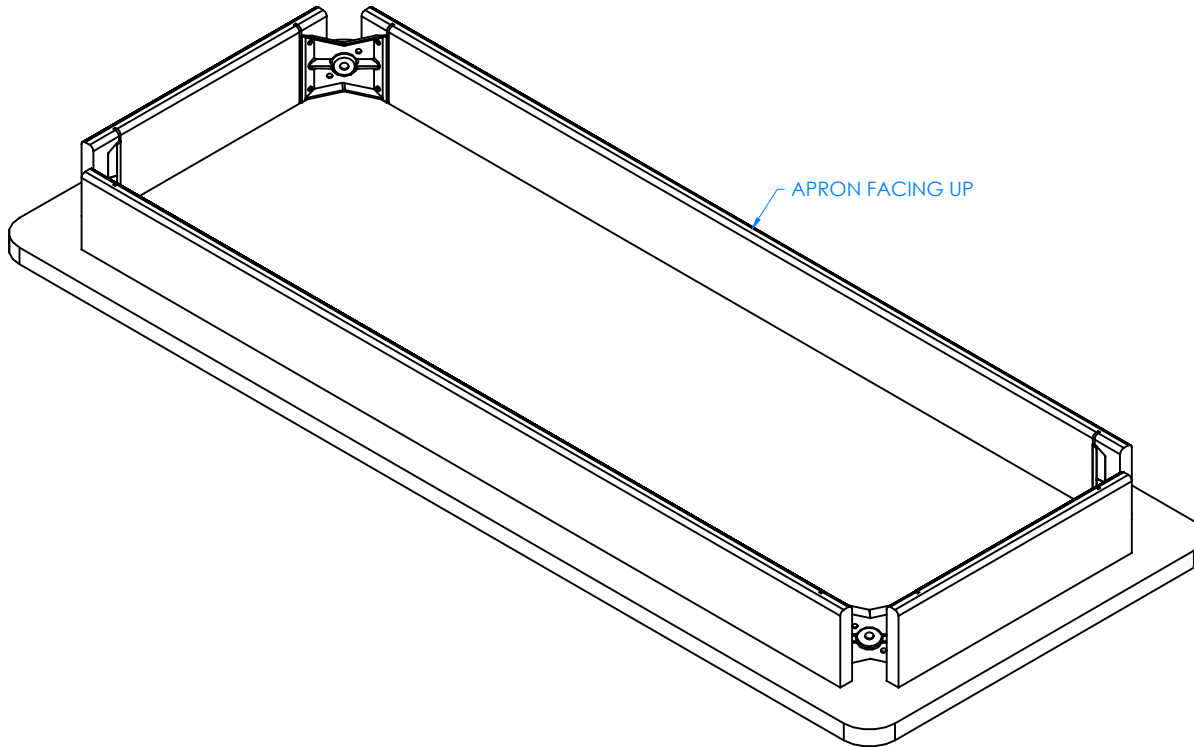

STEP 1:

- LAY TOP ASSEMBLY ON FLOOR UPSIDE DOWN WITH APRON FACING UP

****NOTE****
BE SURE TOP ASSEMBLY IS ON A CLEAN SURFACE SUCH AS PACKAGING FOAM, CARDBOARD, OR A BLANKET TO PREVENT DAMAGE

NOTE:

- 1.

ALL DIMENSIONS ARE IN INCHES UNLESS NOTED OTHERWISE	DWN BY:	EMR	DATE DWN:	5/5/20
DECIMALS: $\frac{1}{16}$ = ± .030	APR BY:		DATE APR:	
XX = ± .020	APR BY:		DATE APR:	
XXX = ± .010	APR BY:		DATE APR:	
ANGLES: = ± 1°	APR BY:		DATE APR:	
CABINET SQUARENESS: = ± .0625	APR BY:		DATE APR:	



CONFIDENTIAL:
ALL DESIGN RIGHTS RESERVED
THE INFORMATION, DATA, DESIGN, AND DRAWINGS EMBODIED IN THIS DOCUMENT AND ALL REPRODUCTIONS THEREOF ARE THE EXCLUSIVE PROPERTY OF DIVERSIFIED WOODCRAFTS, INC.

TITLE:
STANDARD TABLES - WOOD LEGS
ASSEMBLY INSTRUCTIONS

THESE DOCUMENTS ARE SUPPLIED WITH THE UNDERSTANDING THAT THEY WILL NOT BE DISCLOSED TO THIRD PARTIES WITHOUT WRITTEN CONSENT OF DIVERSIFIED WOODCRAFTS, INC. ANY REPRODUCTION IN PART OR WHOLE WITHOUT WRITTEN CONSENT IS SUBJECT TO LEGAL ACTION.

REV.	DESCRIPTION	DATE	NAME	ECN NO.
A	CREATED ASSEMBLY INSTRUCTIONS	5/5/20	EMR	-
REVISION LEVEL				

DRAWING NUMBER:	SCALE:	SHEET:	REVISION:
P7, C7, & D7 SERIES TABLES	NTS	3 OF 10	REV A

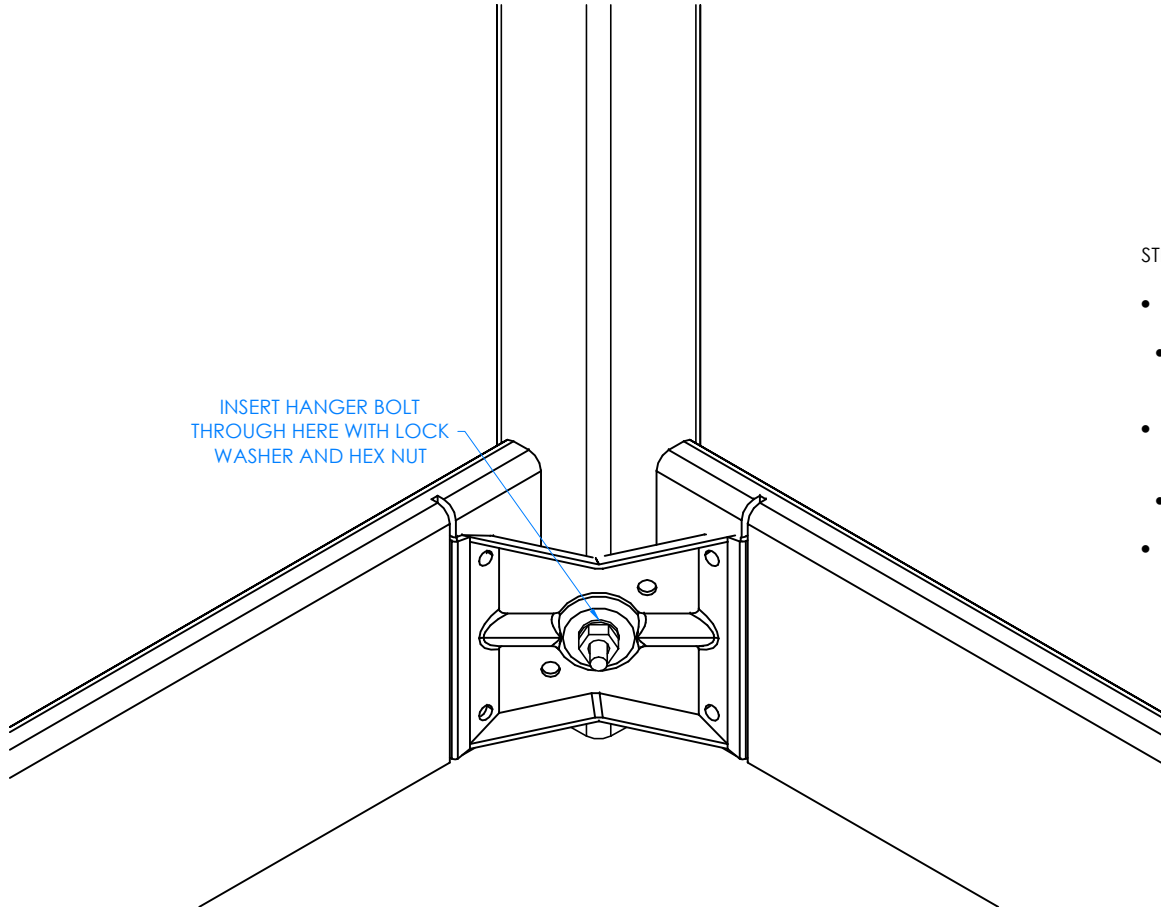

CLOSE UP OF CORNER LEG ASSEMBLY

STEP 2:

- INSERT HANGER BOLT ON ONE LEG THROUGH THE CORNER BRACKET AND INSERT LOCK WASHER AND HEX NUT (FROM 520001-4)
- NOTE: IF YOUR TABLE HAS LEG BRACES, MAKE NOTE OF THE HOLE DIRECTIONS FOR THE LEG BRACE HARDWARE. LEGS WILL NOT BE IDENTICAL - THERE WILL BE (2) LEFT-HAND AND (2) RIGHT-HAND LEGS
- TIGHTEN NUT ONTO HANGER BOLT USING A CRESCENT WRENCH, 1/2" WRENCH OR 1/2" SOCKET AND TORQUE WRENCH, TIGHTEN TO A MINIMUM OF 12FT LBS BUT NOT TO EXCEED 17FT LBS
- NOTE: IF YOUR TABLE HAS BRACES AND STRETCHERS, DO NOT YET TIGHTEN NUTS TO TORQUE. SEE STEP 4 AND 5 FOR CLARIFICATION
- REPEAT FOR OTHER LEGS

NOTE:

- 1.

ALL DIMENSIONS ARE IN INCHES UNLESS NOTED OTHERWISE	DWN BY:	EMR	DATE DWN:	5/5/20
DECIMALS: .X = ± .030	APR BY:		DATE APR:	
.XX = ± .020	APR BY:		DATE APR:	
.XXX = ± .010	APR BY:		DATE APR:	
ANGLES: = ± 1°				
CABINET SQUARENESS: = ± .0625				



CONFIDENTIAL:
 ALL DESIGN RIGHTS RESERVED
 THE INFORMATION, DATA, DESIGN, AND DRAWINGS EMBODIED IN THIS DOCUMENT AND ALL REPRODUCTIONS THEREOF ARE THE EXCLUSIVE PROPERTY OF DIVERSIFIED WOODCRAFTS, INC.

TITLE:
 STANDARD TABLES - WOOD LEGS
 ASSEMBLY INSTRUCTIONS

THESE DOCUMENTS ARE SUPPLIED WITH THE UNDERSTANDING THAT THEY WILL NOT BE DISCLOSED TO THIRD PARTIES WITHOUT WRITTEN CONSENT OF DIVERSIFIED WOODCRAFTS, INC. ANY REPRODUCTION IN PART OR WHOLE WITHOUT WRITTEN CONSENT IS SUBJECT TO LEGAL ACTION.

DRAWING NUMBER:	SCALE:	SHEET:	REVISION:
P7, C7, & D7 SERIES TABLES	NTS	4 OF 10	REV A

REV.	DESCRIPTION	DATE	NAME	ECN NO.
A	CREATED ASSEMBLY INSTRUCTIONS	5/5/20	EMR	-
REVISION LEVEL				

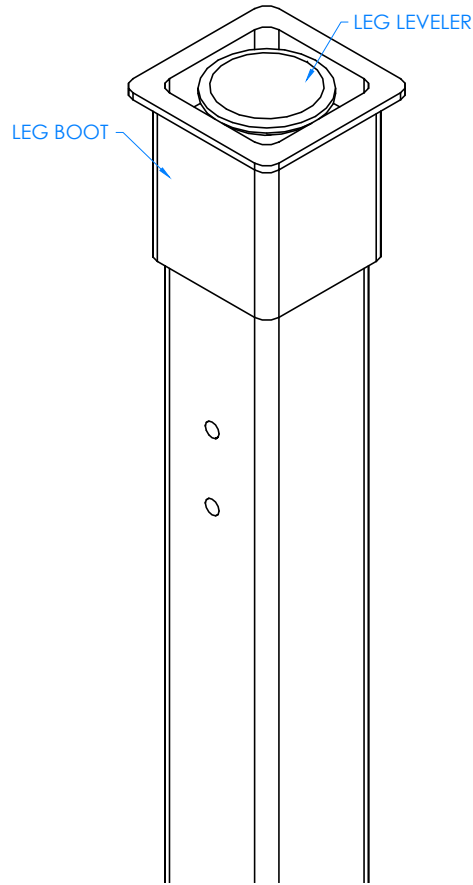

CLOSE UP OF LEG BOOT AND LEG LEVELER ASSEMBLY

STEP 3:

- SLIDE LEG BOOTS (100076) ONTO LEGS WITH FLARED END TOWARD BOTTOM OF LEG
- THREAD LEG LEVELERS (FROM 520001-4) INTO T-NUT ON BOTTOM OF LEGS

NOTE:

1.

ALL DIMENSIONS ARE IN INCHES UNLESS NOTED OTHERWISE	DWN BY:	EMR	DATE DWN:	5/5/20
DECIMALS: .X = ± .020	APR BY:		DATE APR:	
.XX = ± .020	APR BY:		DATE APR:	
.XXX = ± .010	APR BY:		DATE APR:	
ANGLES: = ± 1°	APR BY:		DATE APR:	
CABINET SQUARENESS: = ± .0625	APR BY:		DATE APR:	



CONFIDENTIAL:
ALL DESIGN RIGHTS RESERVED
THE INFORMATION, DATA, DESIGN, AND DRAWINGS EMBODIED IN THIS DOCUMENT AND ALL REPRODUCTIONS THEREOF ARE THE EXCLUSIVE PROPERTY OF DIVERSIFIED WOODCRAFTS, INC.

TITLE:
STANDARD TABLES - WOOD LEGS
ASSEMBLY INSTRUCTIONS

THESE DOCUMENTS ARE SUPPLIED WITH THE UNDERSTANDING THAT THEY WILL NOT BE DISCLOSED TO THIRD PARTIES WITHOUT WRITTEN CONSENT OF DIVERSIFIED WOODCRAFTS, INC. ANY REPRODUCTION IN PART OR WHOLE WITHOUT WRITTEN CONSENT IS SUBJECT TO LEGAL ACTION.

REV.	DESCRIPTION	DATE	NAME	ECN NO.
A	CREATED ASSEMBLY INSTRUCTIONS	5/5/20	EMR	-

REVISION LEVEL

DRAWING NUMBER:	SCALE:	SHEET:	REVISION:
P7, C7, & D7 SERIES TABLES	NTS	5 OF 10	REV A

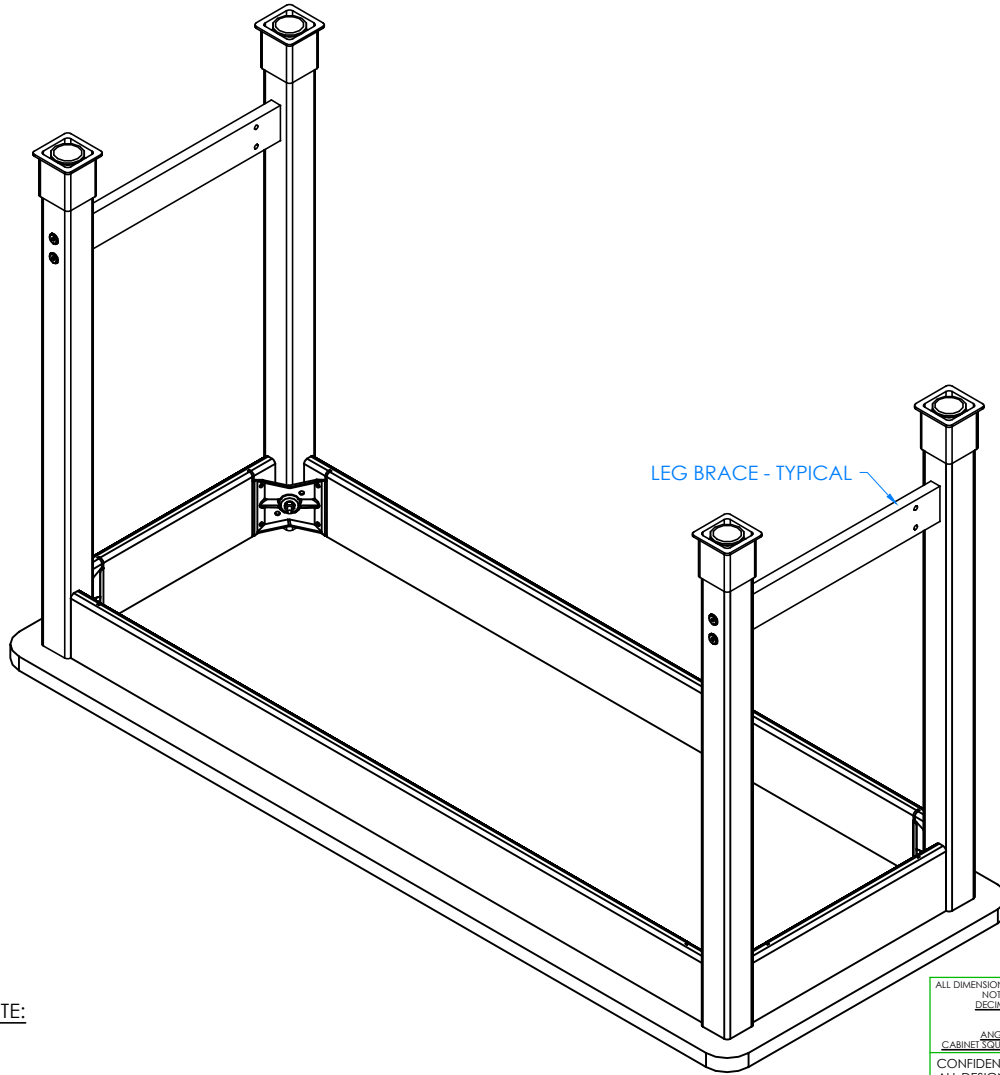

STEP 4:

- IF YOUR TABLE DOES NOT HAVE LEG BRACES AND STRETCHERS, SKIP TO STEP 6
- HOLD BRACE IN POSITION BETWEEN LEGS
 - NOTE: IF YOUR TABLE HAS AN OFFSET STRETCHER, MAKE NOTE OF BRACE POSITIONING AS THE HOLES FOR THE STRETCHER WILL BE OFFSET
- INSERT CONFIRMATS (227578) THROUGH LEG AND SCREW INTO BRACE
- REPEAT FOR OTHER LEGS
- MAKE SURE BRACES ARE STRAIGHT AND ALL CONFIRMATS TIGHT

NOTE:

1.

ALL DIMENSIONS ARE IN INCHES UNLESS NOTED OTHERWISE	DWN BY:	EMR	DATE DWN:	5/5/20
DECIMALS: X = ± .020	APR BY:		DATE APR:	
XX = ± .020	APR BY:		DATE APR:	
XXX = ± .010	APR BY:		DATE APR:	
ANGLES: = ± 1°	APR BY:		DATE APR:	
CABINET SQUARENESS: = ± .0625	APR BY:		DATE APR:	



CONFIDENTIAL:
 ALL DESIGN RIGHTS RESERVED
 THE INFORMATION, DATA, DESIGN, AND DRAWINGS EMBODIED IN THIS DOCUMENT AND ALL REPRODUCTIONS THEREOF ARE THE EXCLUSIVE PROPERTY OF DIVERSIFIED WOODCRAFTS, INC.

TITLE:
 STANDARD TABLES - WOOD LEGS
 ASSEMBLY INSTRUCTIONS

THESE DOCUMENTS ARE SUPPLIED WITH THE UNDERSTANDING THAT THEY WILL NOT BE DISCLOSED TO THIRD PARTIES WITHOUT WRITTEN CONSENT OF DIVERSIFIED WOODCRAFTS, INC. ANY REPRODUCTION IN PART OR WHOLE WITHOUT WRITTEN CONSENT IS SUBJECT TO LEGAL ACTION.

DRAWING NUMBER:	SCALE:	SHEET:	REVISION:
P7, C7, & D7 SERIES TABLES	NTS	6 OF 10	REV A

REV.	DESCRIPTION	DATE	NAME	ECN NO.
A	CREATED ASSEMBLY INSTRUCTIONS	5/5/20	EMR	-
REVISION LEVEL				

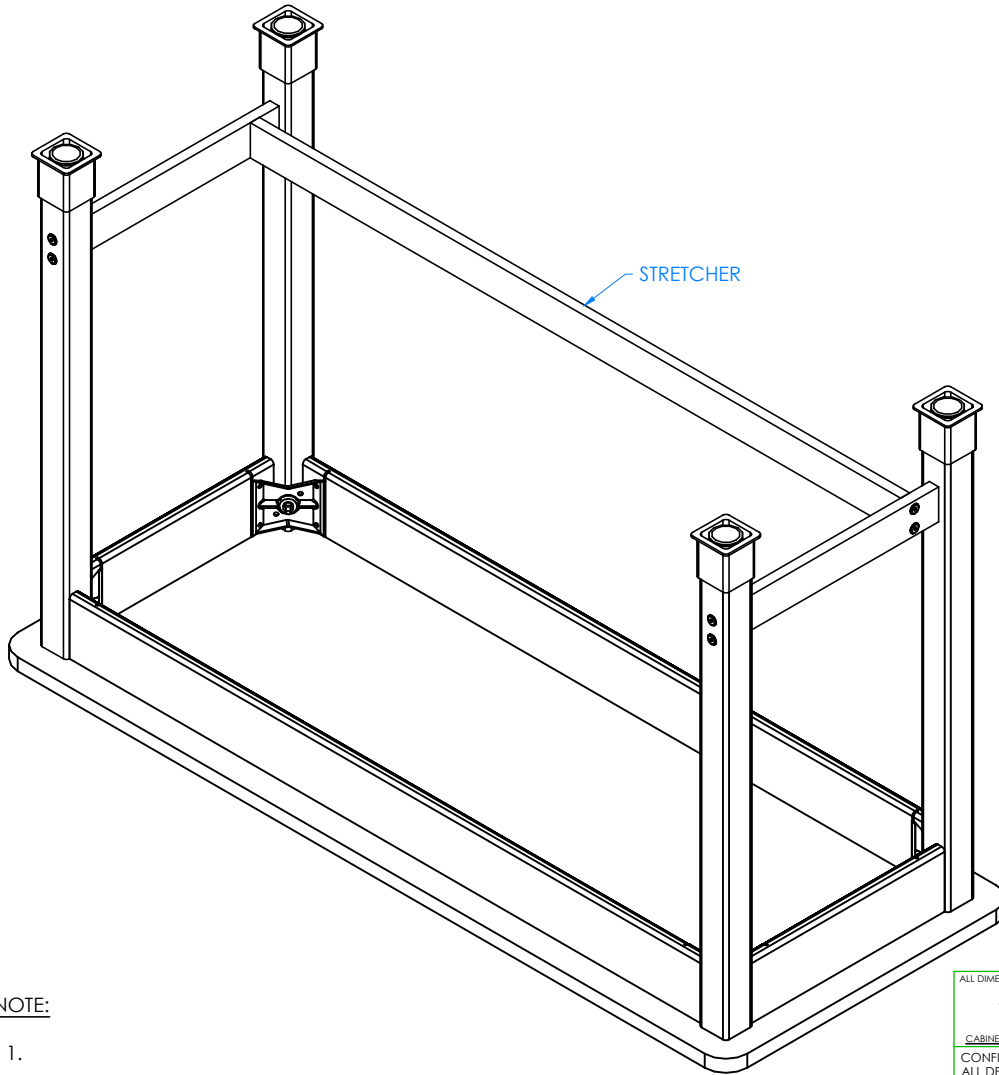

STEP 5:

- HOLD STRETCHER IN PLACE BETWEEN BRACES
- INSERT CONFIRMATS (228564) THROUGH BRACES AND SCREW INTO STRETCHER
- MAKE SURE STRETCHER IS STRAIGHT AND ALL CONFIRMATS TIGHT
- TIGHTEN NUTS ON HANGER BOLTS FROM STEP 2 USING A 1/2" WRENCH OR 1/2" SOCKET AND TORQUE WRENCH, TIGHTEN TO A MINIMUM OF 12FT LBS BUT NOT TO EXCEED 17FT LBS.
- NOTE: TABLES OVER 36" DEEP WITH FULL DEPTH SHELVES WILL RECEIVE (2) STRETCHERS

NOTE:

1.

ALL DIMENSIONS ARE IN INCHES UNLESS NOTED OTHERWISE	DWN BY:	EMR	DATE DWN:	5/5/20
DECIMALS: X = ± .030	APR BY:		DATE APR:	
XX = ± .020	APR BY:		DATE APR:	
XXX = ± .010	APR BY:		DATE APR:	
ANGLES: = ± 1°	APR BY:		DATE APR:	
CABINET SQUARENESS: = ± .0625	APR BY:		DATE APR:	



CONFIDENTIAL:
 ALL DESIGN RIGHTS RESERVED
 THE INFORMATION, DATA, DESIGN, AND DRAWINGS EMBODIED IN THIS DOCUMENT AND ALL REPRODUCTIONS THEREOF ARE THE EXCLUSIVE PROPERTY OF DIVERSIFIED WOODCRAFTS, INC.

TITLE:
 STANDARD TABLES - WOOD LEGS
 ASSEMBLY INSTRUCTIONS

THESE DOCUMENTS ARE SUPPLIED WITH THE UNDERSTANDING THAT THEY WILL NOT BE DISCLOSED TO THIRD PARTIES WITHOUT WRITTEN CONSENT OF DIVERSIFIED WOODCRAFTS, INC. ANY REPRODUCTION IN PART OR WHOLE WITHOUT WRITTEN CONSENT IS SUBJECT TO LEGAL ACTION.

DRAWING NUMBER:	SCALE:	SHEET:	REVISION:
P7, C7, & D7 SERIES TABLES	NTS	7 OF 10	REV A

REV.	DESCRIPTION	DATE	NAME	ECN NO.
A	CREATED ASSEMBLY INSTRUCTIONS	5/5/20	EMR	-
REVISION LEVEL				

STEP 6:

- IF YOUR TABLE DOES *NOT* HAVE A SHELF, SKIP TO STEP 7
- WITH HELP FROM ANOTHER PERSON, TIP TABLE ON ITS SIDE
- ATTACH SHELF TO STRETCHER AND BRACES BY SCREWING UP THROUGH POCKET HOLES IN STRETCHER AND BRACES USING PROVIDED WOOD SCREWS (100066)
- NOTE: HALF DEPTH SHELVES ARE TO BE CENTERED ON ALL DOUBLE SIDED TABLES (OVER 24" DEEP) BUT ARE TO BE OFFSET TO THE BACK AND OVER THE STRETCHERS ON SINGLE SIDED (UNDER 24" DEEP) TABLES

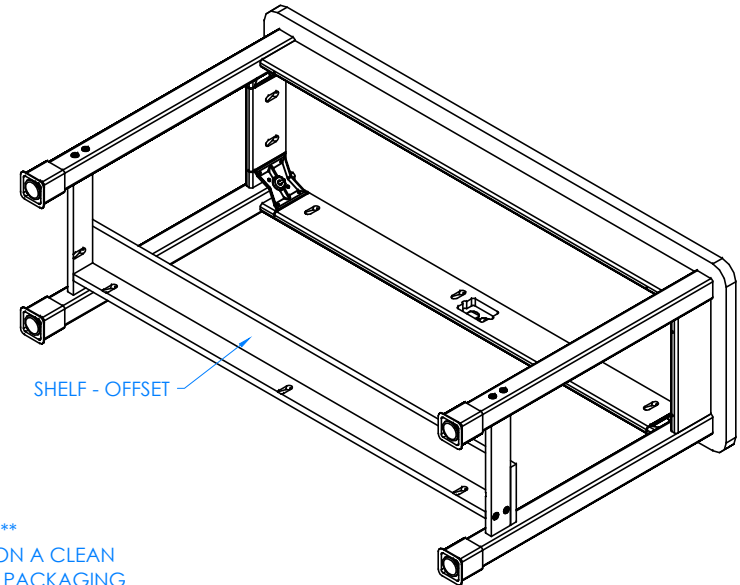
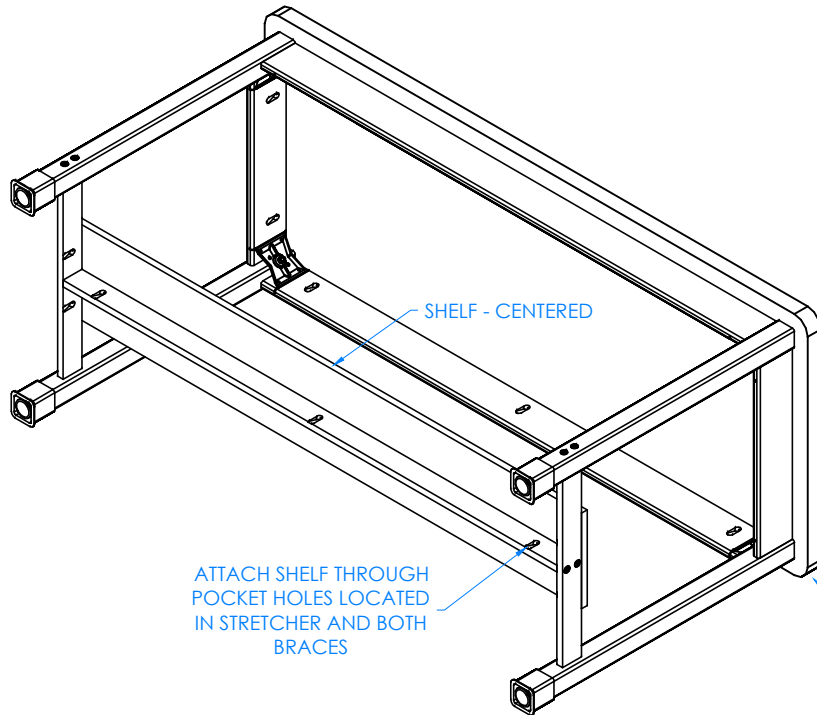

****NOTE****
BE SURE TABLE IS ON A CLEAN SURFACE SUCH AS PACKAGING FOAM, CARDBOARD, OR A BLANKET TO PREVENT DAMAGE

HALF WIDTH SHELF SHOWN ON TABLE UNDER 24" DEEP

NOTE:

1.

HALF WIDTH SHELF SHOWN ON TABLE OVER 24" DEEP

ALL DIMENSIONS ARE IN INCHES UNLESS NOTED OTHERWISE	DWN BY:	EMR	DATE DWN:	5/5/20
DECIMALS: X = ± .030 XX = ± .020 XXX = ± .010	APR BY:		DATE APR:	
ANGLES: = ± 1°	APR BY:		DATE APR:	
CABINET SQUARENESS: = ± .0625				

CONFIDENTIAL:
ALL DESIGN RIGHTS RESERVED
THE INFORMATION, DATA, DESIGN, AND DRAWINGS EMBODIED IN THIS DOCUMENT AND ALL REPRODUCTIONS THEREOF ARE THE EXCLUSIVE PROPERTY OF DIVERSIFIED WOODCRAFTS, INC.

THESE DOCUMENTS ARE SUPPLIED WITH THE UNDERSTANDING THAT THEY WILL NOT BE DISCLOSED TO THIRD PARTIES WITHOUT WRITTEN CONSENT OF DIVERSIFIED WOODCRAFTS, INC. ANY REPRODUCTION IN PART OR WHOLE WITHOUT WRITTEN CONSENT IS SUBJECT TO LEGAL ACTION.



TITLE:
STANDARD TABLES - WOOD LEGS
ASSEMBLY INSTRUCTIONS

REV.	DESCRIPTION	DATE	NAME	ECN NO.
A	CREATED ASSEMBLY INSTRUCTIONS	5/5/20	EMR	-

REVISION LEVEL

DRAWING NUMBER:	SCALE:	SHEET:	REVISION:
P7, C7, & D7 SERIES TABLES	NTS	8 OF 10	REV A

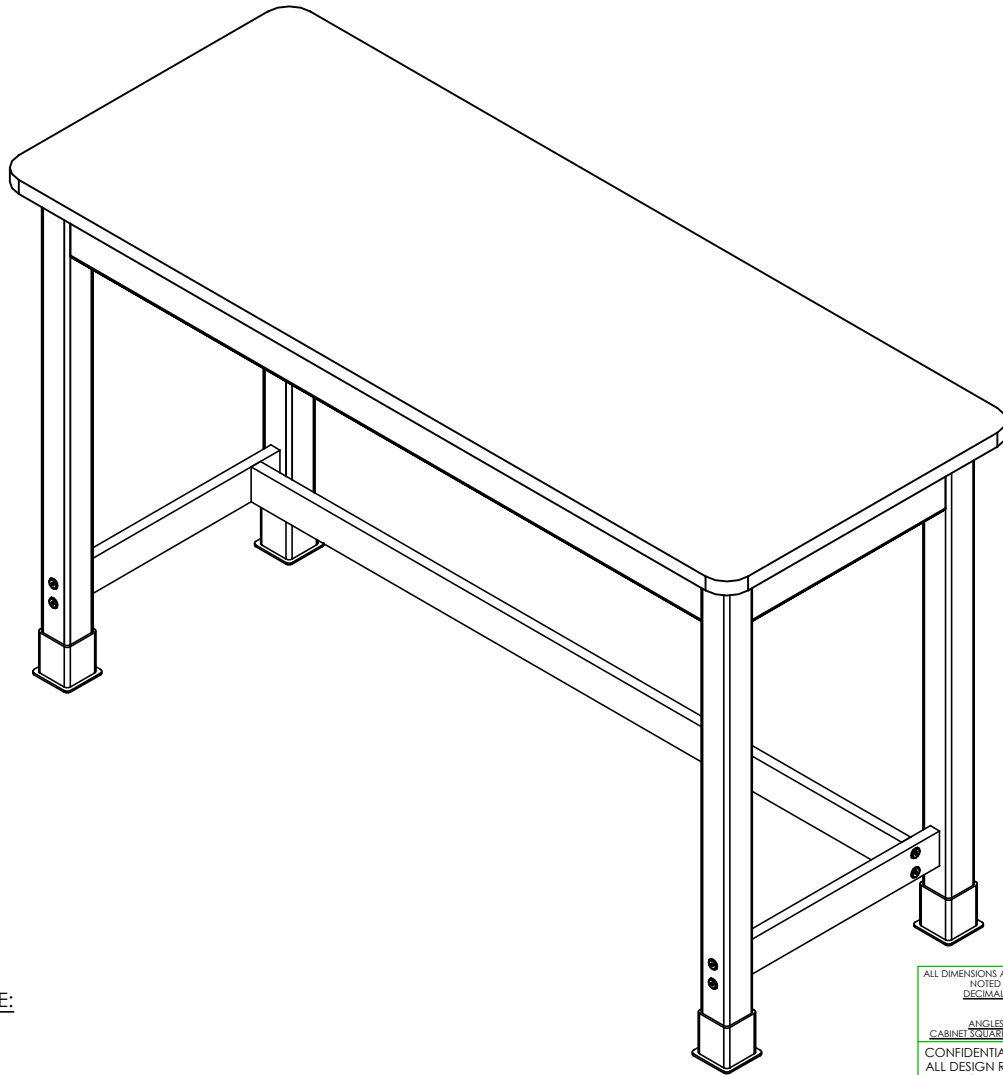

STEP 7:

- TURN TABLE UPRIGHT
- SET TABLE IN PLACE
- ADJUST LEG LEVELERS TO LEVEL TABLE AS NECESSARY
- SLIDE LEG BOOTS DOWN TO FLOOR
- IF YOUR TABLE HAS DRAWERS, PLACE DRAWERS INTO OPENINGS

NOTE:

1.

COMPLETE UNIT SHOWN

REV.	DESCRIPTION	DATE	NAME	ECN NO.
A	CREATED ASSEMBLY INSTRUCTIONS	5/5/20	EMR	-
REVISION LEVEL				

ALL DIMENSIONS ARE IN INCHES UNLESS NOTED OTHERWISE	DWN BY:	EMR	DATE DWN:	5/5/20
DECIMALS: X = ± .030	APR BY:		DATE APR:	
XX = ± .020	APR BY:		DATE APR:	
XXX = ± .010	APR BY:		DATE APR:	
ANGLES: = ± 1°	APR BY:		DATE APR:	
CABINET SQUARENESS: = ± .0625	APR BY:		DATE APR:	

CONFIDENTIAL:
 ALL DESIGN RIGHTS RESERVED
 THE INFORMATION, DATA, DESIGN, AND DRAWINGS EMBODIED IN THIS DOCUMENT AND ALL REPRODUCTIONS THEREOF ARE THE EXCLUSIVE PROPERTY OF DIVERSIFIED WOODCRAFTS, INC.

THESE DOCUMENTS ARE SUPPLIED WITH THE UNDERSTANDING THAT THEY WILL NOT BE DISCLOSED TO THIRD PARTIES WITHOUT WRITTEN CONSENT OF DIVERSIFIED WOODCRAFTS, INC. ANY REPRODUCTION IN PART OR WHOLE WITHOUT WRITTEN CONSENT IS SUBJECT TO LEGAL ACTION.



TITLE:
 STANDARD TABLES - WOOD LEGS
 ASSEMBLY INSTRUCTIONS

DRAWING NUMBER:	SCALE:	SHEET:	REVISION:
P7, C7, & D7 SERIES TABLES	NTS	9 OF 10	REV A