

ASSEMBLY INSTRUCTIONS

PARTS BAG

5712

DEMCO Newspaper Tower

Parts	Quantity	Reference
#10 x 5/8" Trusshead Screw	34	A
50mm One-Piece Connector Bolt	3	B
Hex Key	1	C

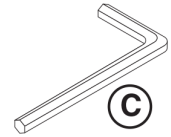
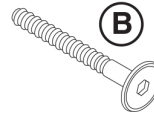
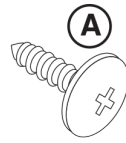

PARTS LIST

Parts	Quantity	Reference
Side Panels	3	D
Base Plate	1	E
Racks	15	F
Corner Extrusion	3	G
Top Cap	1	H

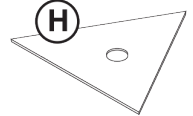
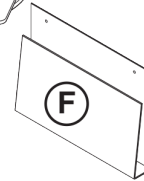
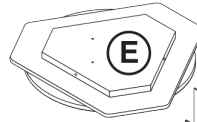
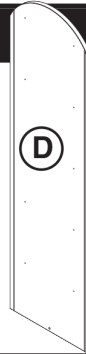

STEP 1

!! IMPORTANT !!

Before assembly be sure to remove the (2) Support Bolts & (2) Wing Nuts, so that the base plate spins properly.

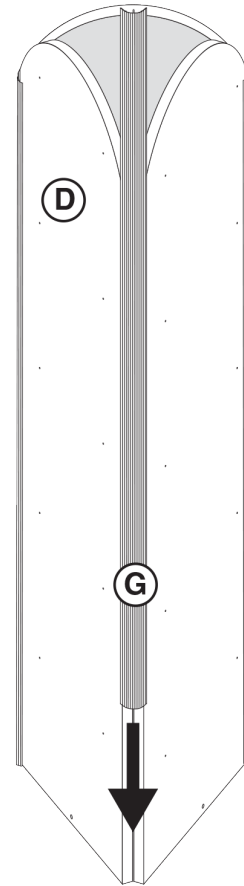
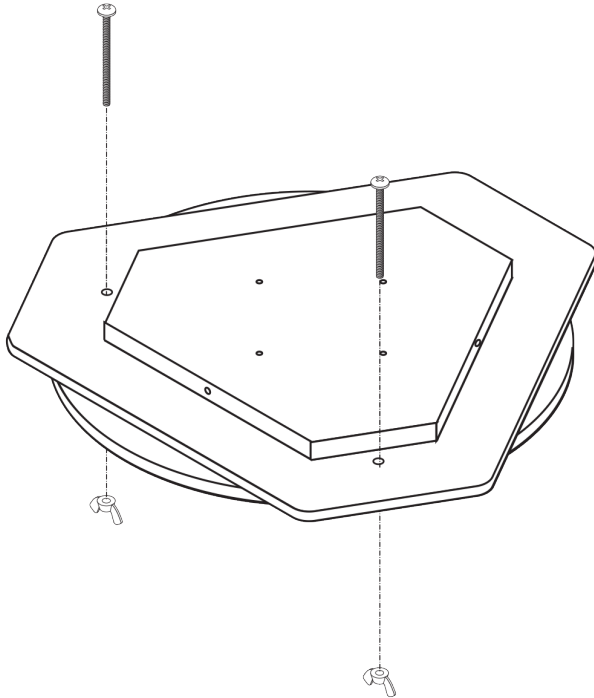

Put together (3) **Side Panels (D)** using (3) **Corner Extrusions (G)**, as shown in illustration.

STEP 2

Attach assembly to the **Spinner Base (E)** using (3) **50mm One Piece Connecting Bolts (B)**, as shown.

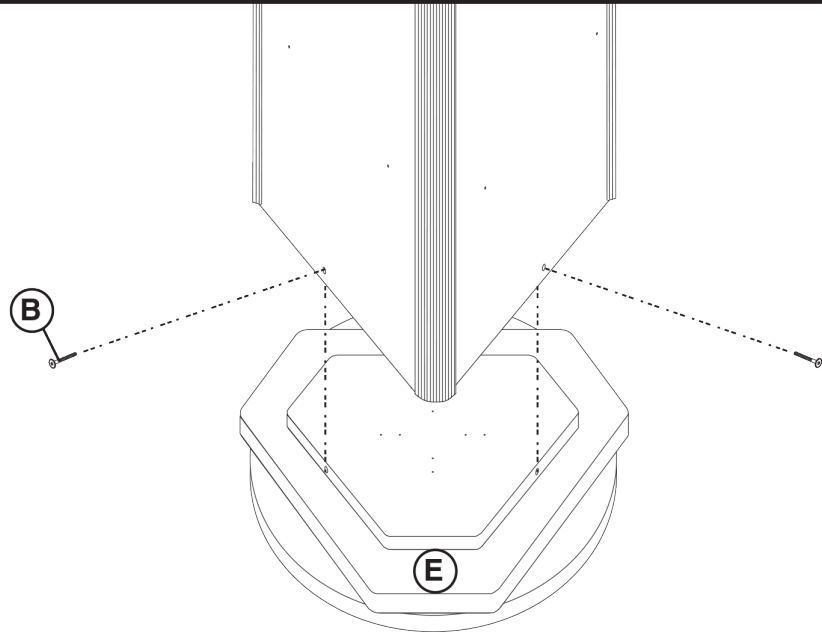

STEP 3

NOTE: Peel masking film from **Racks (F)** before assembling.

Connect **Racks (F)** to fixture using **#10 x 5/8" Trusshead Screws (A)**. Install **Top Cap (H)** inserting in top center opening and resting on tops of **Corner Extrusions (G)**.

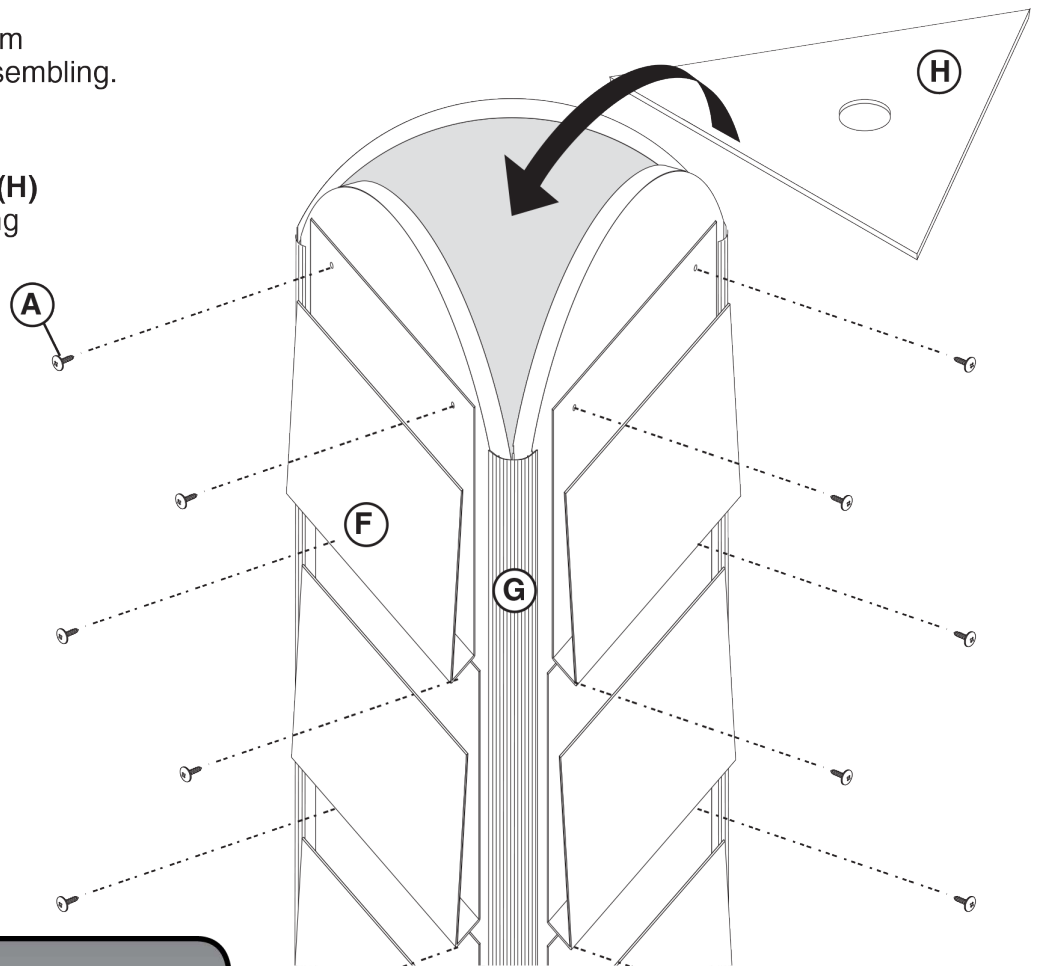

demco[®]
imagine what's possible™

Find Demco[®] Magazine/Newspaper Towers @demco.com
Search: 1493561

Call 800.962.4463 or email custserv@demco.com